

PD10 & PD15 Models

Specifications & Capacities		
	PD10	PD15
Tractor Horsepower Range	15 to 30 horsepower (11.2 to 22.4 kw)	20 to 40 horsepower (14.9 to 29.8 kw)
Weight Without Auger	120 lbs (54.4 kg)	161 lbs (73.0 kg)
Auger Length	30" (76.2 cm)	48" (1.22 m)
Auger Flight Thickness	1/4" (6 mm)	
Auger Pipe	2 1/2" (6.4 cm) ID	
Auger Teeth	Forged, Individually Replaceable 40 Degree angle installed on flat side 50 Degree angle installed on angled side	
Number of Teeth	6" (15.2 cm) - 2 teeth 9" & 12" (22.9 cm & 30.5 cm) - 4 teeth	
Pilot	Cast steel, 3 drill points	
Driveline	Cat. II Shearbolt	
Maximum Operating power take-off Speed	300 rpm	
Gearbox	1 3/8" (3.5 cm) 6B spline input shaft, 3:1 Ratio	1 3/8" (3.5 cm) 6B spline input shaft, 3.18:1 Ratio
Gearbox Oil Capacity & Type	3.4 Pints (1.61 L) of SAE80-90W EP oil	4.6 (2.18 L) Pints of SAE80-90W EP oil
Output Shaft	2" (5.1 cm) O.D. Round	
3-Point Hitch Cat.	Cat. I	
Boom	2 7/8" (7.3 cm) O.D.	
Yoke	2 7/8" (7.3 cm) O.D.	
Options and Accessories		
Auger Extensions (Accessory)	7" & 14" (17.8 cm & 35.6 cm) Extensions Available	
Dirt Auger Sizes (Option)	6", 9", or 12" (15.2, 22.9, or 30.5 cm)	6", 9", 12", 15", & 18" (15.2, 22.9, 30.5, 38.1, & 45.7 cm)
Bolt-on Rock Head (Accessory)	Not Available	6", 9", 12", 15", & 18" (15.2, 22.9, 30.5, 38.1, & 45.7 cm)
Rock Auger Sizes (Option)	Not Available	6", 9", 12", 15", & 18" (15.2, 22.9, 30.5, 38.1, & 45.7 cm)
Cat. III Torque Limiter Driveline	Not Available	Not Available
Hydraulic Down Pressure Kit	Available	Available
Storage Stand	Available	Available

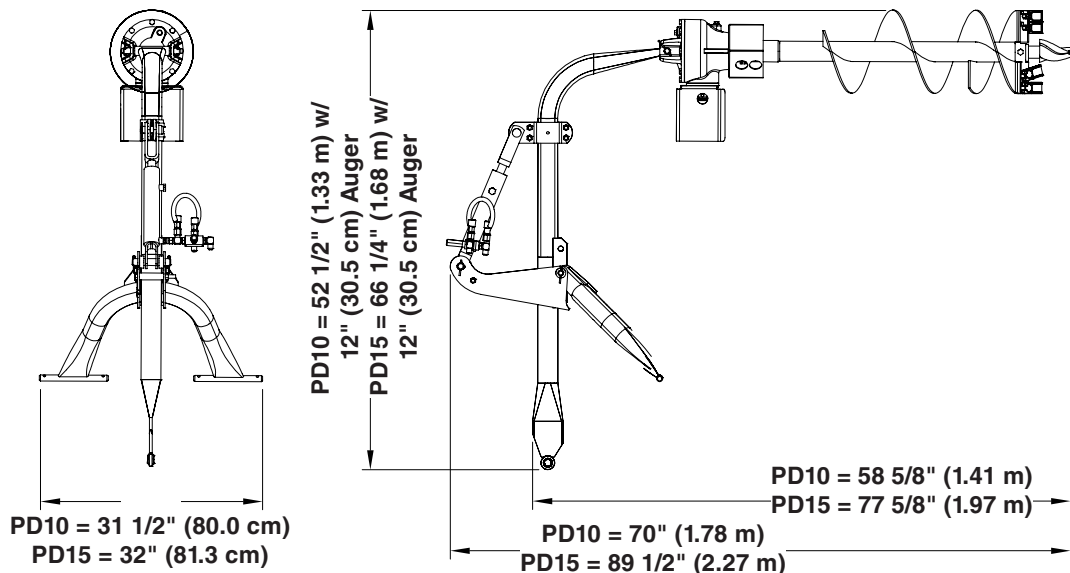

PD10 & PD15 Overall Dimensional Drawing

26776

PD25 & PD35 Models

Specifications & Capacities		
	PD25	PD35
Tractor horsepower range	25 to 55 horsepower (18.6 to 41.0 kw)	30 to 75 horsepower (22.4 to 55.9 kw)
Weight without auger	186 lbs (84.4 kg)	233 lbs (105.7 kg)
Auger length	48" (1.22 m)	
Auger flight thickness	1/4" (6 mm)	
Auger pipe	2 1/2" (6.4 cm) ID	
Auger tooth construction	Forged, individually replaceable 40 Degree angle installed on flat side 50 Degree angle installed on angled side	
Number of teeth	(6" (15.2 cm) - 2 teeth) (9" & 12" (22.9 cm & 30.5 cm) - 4 teeth) (15" (38.1 cm) - 5 teeth) (18" (45.7 cm) - 6 teeth) (24" (61.0 cm) - 8 teeth)	
Pilot	Cast steel, 3 drill points	
Driveline Cat.	Cat. III shear bolt - standard	Cat. III radial pin clutch - optional (Recommended on auger sizes 15" (38.1 cm) and above.)
Maximum operating power take-off Speed	300 rpm	
Gearbox	1 3/8" (3.5 cm) 6B spline input shaft 3.18:1 Ratio	1 3/8" (3.5 cm) 6B spline input shaft 4:1 Ratio
Gearbox oil capacity & type	4.6 Pints (2.18 L) of SAE80-90W EP oil	9.1 Pints (4.31 L) of SAE80-90W EP oil
Output shaft	2" (5.1 cm) O.D. Round	
3-Point hitch Cat.	Cat. I & II	
Boom	3 1/2" (8.9 cm) O.D.	3 1/2" (8.9 cm) O.D.
Yoke	2 7/8" (7.3 cm) O.D.	
Options and Accessories		
Auger extensions (accessory)	7" & 14" (17.8 cm & 35.6 cm) Extensions Available	
Dirt auger sizes (option)	6", 9", 12", 15", or 18" (15.2 cm, 22.9 cm, 30.5 cm, 38.1 cm, & 45.7 cm)	
Bolt-on rock head (accessory)	6", 9", 12", 15", or 18" (15.2 cm, 22.9 cm, 30.5 cm, 38.1 cm, & 45.7 cm)	
Rock auger sizes (option)	6", 9", 12", 15", or 18" (15.2 cm, 22.9 cm, 30.5 cm, 38.1 cm, & 45.7 cm)	
Tree auger size	24" (61.0 cm)	
Cat. III torque limiter driveline	Available	Available
Hydraulic down pressure kit	Available	Available
Storage stand	Available	Available

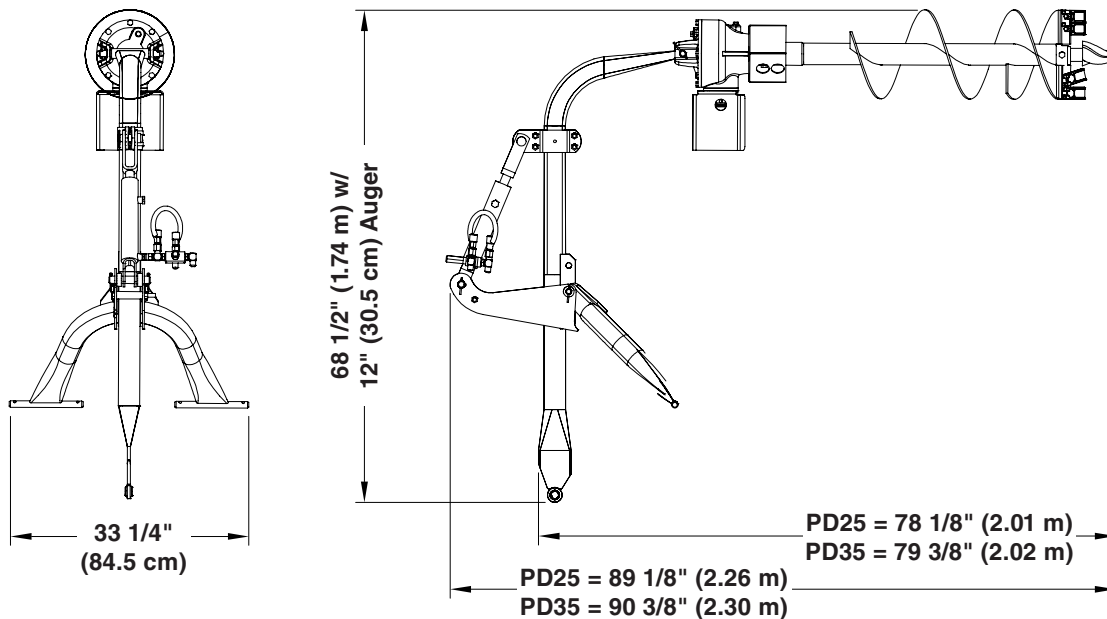

PD25 & PD35 Overall Dimensional Drawing

26776