

FDR25 Series Rear Discharge Mowers

Specifications & Capacities		
Model Numbers	FDR2572	FDR2584
Maximum Horsepower - Engine	60 horsepower	
Cutting Width	72"	84"
Overall Width	74 7/8"	86 1/2"
Height	35 1/2"	
Length	69"	75"
Weight	718#	812#
Cutting Height (1/2" increments)	3/4" - 5 1/4"	
Deck Material Thickness	3/16"	
Blade Tip Speed	18,130 FPM	17,210 FPM
Blades Construction - 3 each	1/4" x 2 1/2" x 25" Heat Treated Alloy Steel	5/16" x 2 1/2" x 29" Heat Treated Alloy Steel
Blade Options	Standard Blades: Medium Lift Optional Blades: Low Lift, High Lift & Mulching	
Blade Overlap	1 1/4"	
Blade Spindles	Greaseable	
Discharge	Rear	
Hitch	Category 1	
Lower Hitch	Floating & Adjustable Clevis with Plated Pins	
Top Link	Floating & Adjustable Clevis	
Castered Gauge Wheels	3 1/4" x 10" Solid Rubber	4" x 11" Semi Solid
Caster Wheel Spindle	1" Diameter with Greaseable Bushing	
Drive Train	540 rpm power take-off Cast Iron Housing Gearbox With Beveled Gears, 1:2.83 Ratio Spring Loaded Single V-Belt	
Gearbox Oil Capacity & Type	3.5 Pints of 80-90W EP Gear Lube	
Driveline	Heavy-duty w/ quick coupler	
Front Roller	Optional	
Quick Hitch Compatible	Fits Land Pride Quick Hitch	

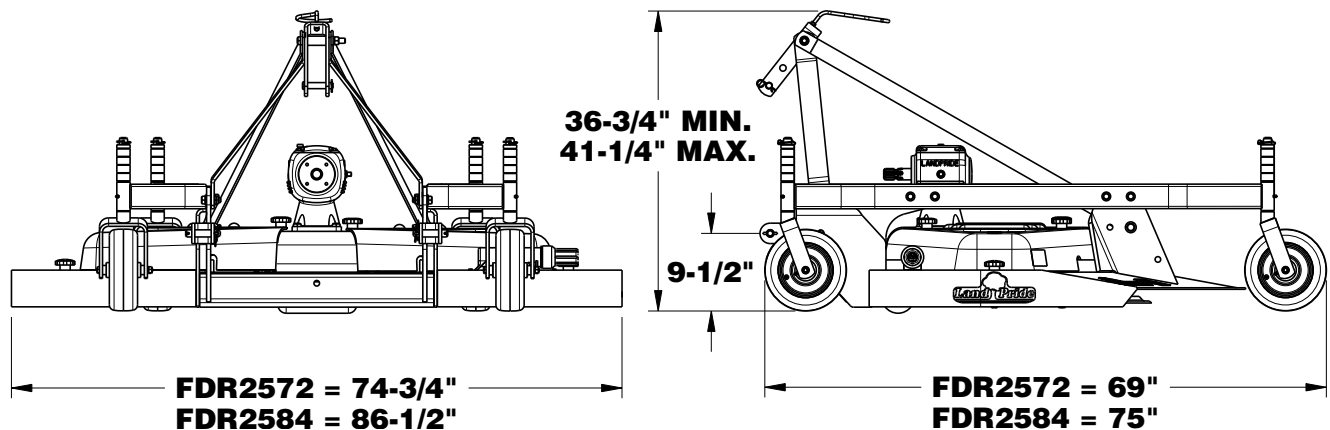

26761