

# Accessory Dash Assembly Instructions



Treker 4200ST & 4400ST Series

Manual No. 700-375M

## Before You Start



**When you see this symbol, the subsequent instructions and warnings are serious - follow without exception. Your life and the lives of others depend on it!**

These optional assembly instructions contain only information required to assemble the accessory dash to the 4200ST & 4400ST Trekers. A detailed Operator's Manual was supplied with the Treker. Refer to the Operator's Manual for additional specific information especially information relating to safety concerns. Also included in the Operator's Manual is important information on operation, adjustment, troubleshooting, and maintenance for this attachment (some manual sections do not apply to all options).

A separate Parts Manual for replacement parts can be purchased from your dealer or available free of charge at [www.landpride.com](http://www.landpride.com). Have model and serial numbers handy when placing an order.

### Manual Part Numbers:

- Treker Operator's Manual .....700-108M
- Treker Parts Manual. ....700-108P

## General Information

These assembly instructions apply to the Accessory Dash Kit for:

**701-113A Treker 4200ST & 4400ST Series**

### Tools required:

- Work Gloves
- Side Diagonal Cutters
- Pencil
- Die Grinder, Jig Saw or Fine Tooth Key Hole Saw
- Center Punch
- Hammer
- Drill with 9/32" Drill Bit
- Extension Cord (if required)
- Two 7/16" box end or open end wrenches
- Phillips Screwdriver
- Spray Bottle with soapy water

## Assembly Instructions

On page 5 is a detailed listing of parts included in this kit. Use this list as a checklist to inventory parts received.

1. Park vehicle on a flat surface, move gear shift lever to forward, set park brake, turn off engine and remove ignition key.

### Refer to Figure 1:

2. Remove existing glove box by pulling tree rivets out. Discard rivets and existing glove box.



**Glove Box Removal  
Figure 1**

### Refer to Figure 2:

3. Disconnect the two wires connected to the 12-Volt Power Plug.
4. Supplied with the kit are two jumper wires. Attach the black jumper wire to the black disconnected wire and the red/black jumper wire to the red/black disconnected wire.

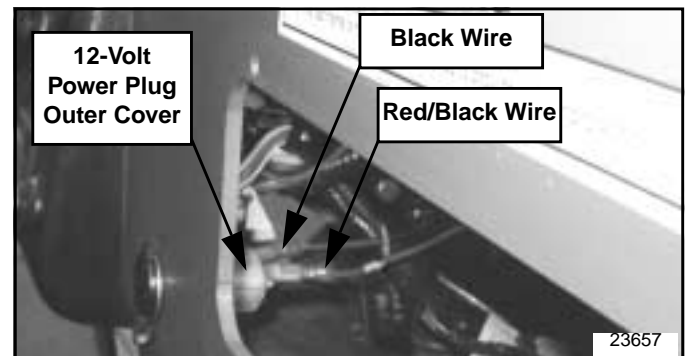

**Power Plug Disassembly  
Figure 2**

### Refer to Figure 2 & Figure 3:

5. Unscrew the power plug outer cover and remove 12 volt power plug. Keep plug for reinstallation.

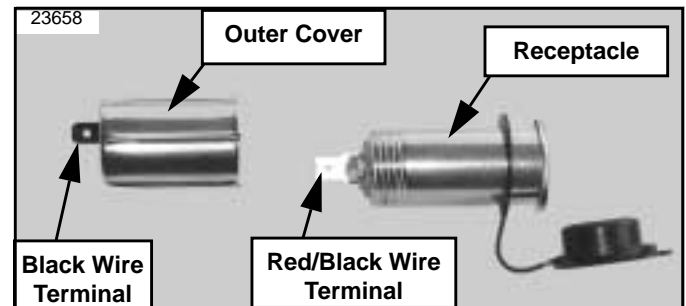

**12 Volt Power Plug Assembly  
Figure 3**

## Assembly Instructions

Refer to Figure 4:

6. Install the 12 volt power plug to the dash under the cup holder.

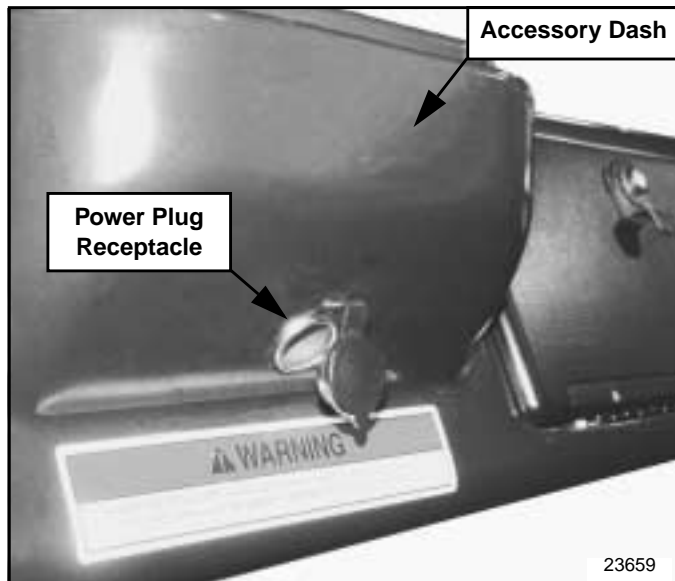

Power Plug Installation  
Figure 4

Refer to Figure 5 & Figure 6:

7. Mark dash glove box and storage pocket cutout openings using the dimensions provided in Figure 6.

**IMPORTANT:** Be careful not to cut any wiring and/or components behind the dash when cutting out the dash openings.

8. Being careful not to cut any wiring and/or components behind the dash, cut-out the storage pocket and glove box opening.

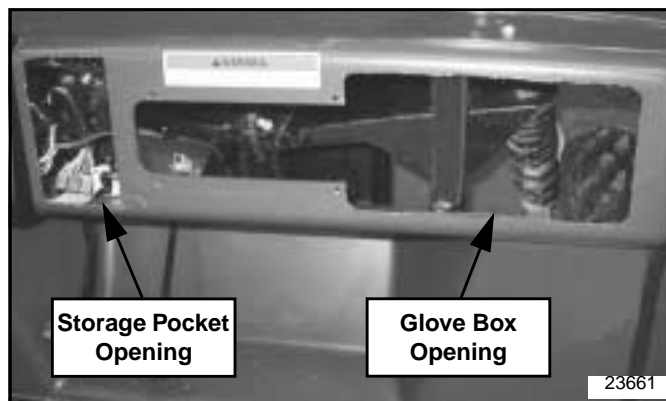

Dash Cut-Out View  
Figure 5

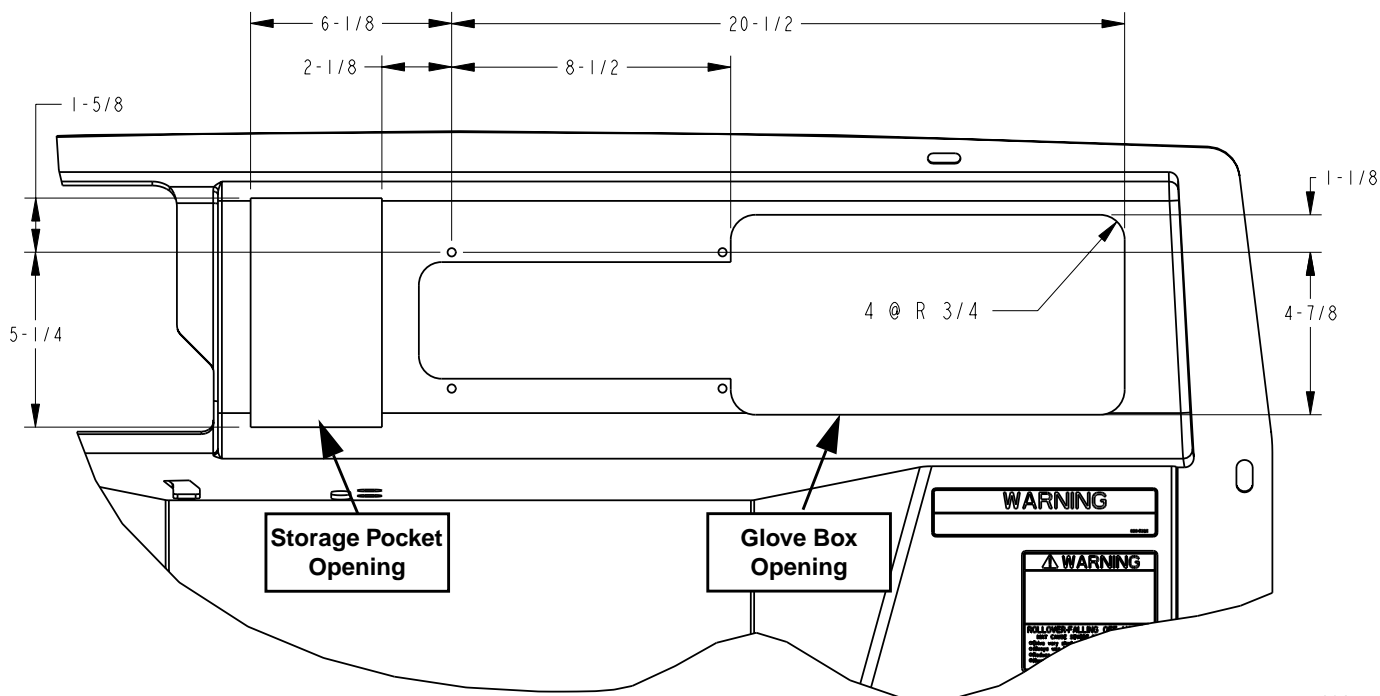

Dimensioned Cut Out Drawing  
Figure 6

## Assembly Instructions

**Refer to Figure 7:**

- Attach dash mounting bracket to existing glove box mounting holes as shown with two 1/4" -20 x 3/4" Gr5 hex head cap screws, 1/4" flat washers and 1/4"-20 hex flange taper lock nut. Washers and nuts to be located behind the dash. Tighten nuts to 8 ft. lbs. of torque.

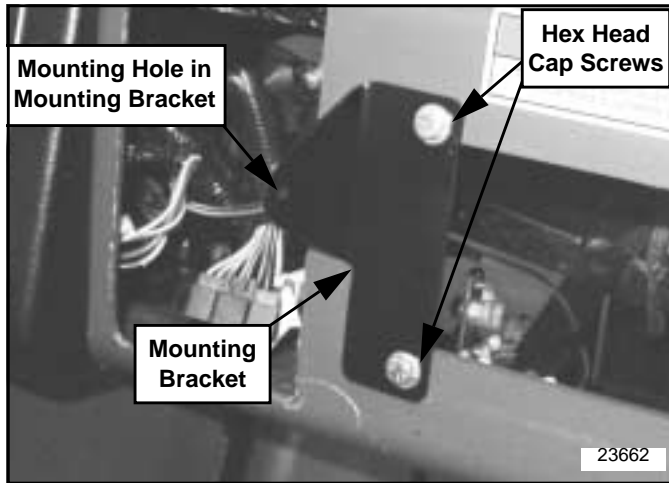

**Dash Mounting Bracket  
Figure 7**

**Refer to Figure 8:**

- Locate the accessory dash over the modified dash. Make certain the hole on the side of the cup holder aligns with the mounting bracket hole and that the dash is properly covering the existing dash. Make a mark on the Treker frame through the mounting hole inside the glove box and then remove the dash.

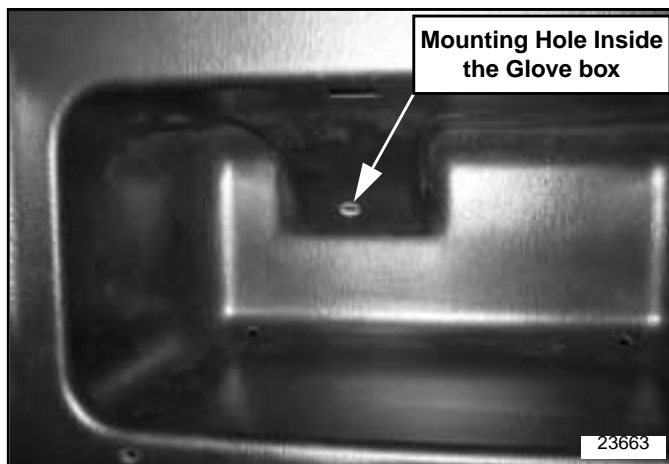

**Mounting Hole Inside The Glove Box  
Figure 8**

**Refer to Figure 9:**

- Center punch the marked spot and drill two 9/32" holes.

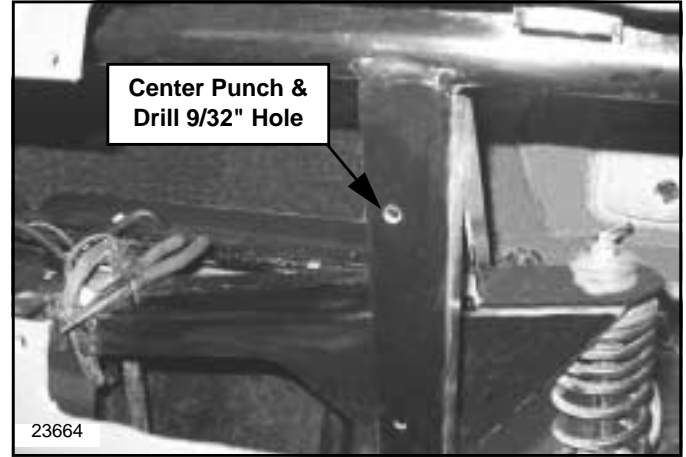

**Mounting Bracket For Glove Box  
Figure 9**

**Refer to Figure 3 on page 1:**

- Connect the black jumper wire to the outer cover of the 12 volt power plug and the red/black jumper wire to the power plug receptacle.

**Refer to Figure 10:**

- Reposition the accessory dash over the modified dash for final assembly.
- Attach the dash to the mounting bracket with one 1/4" removable rivet. Instal rivet by pushing on the head of the rivet. The rivet may be removed by unscrewing the rivet until it is free of the mounting bracket.

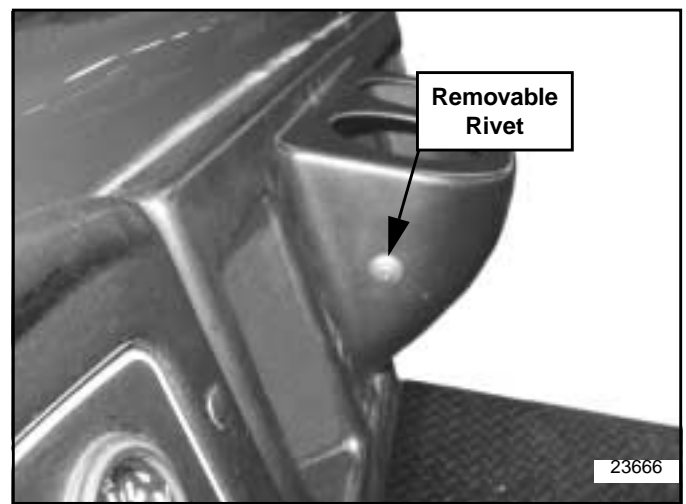

**Attaching to Dash Mounting Bracket  
Figure 10**

## Assembly Instructions

### Refer to Figure 11:

15. Attach the glove box pocket to the mounting bracket with one 1/4"-20 x 3/4" Phillips head machine screw, 1/4" flat washer and 1/4"-20 hex flange taper lock nut. Access the back side of the mounting bracket through the wheel well. Tighten nut to 8 ft. lbs. of torque.

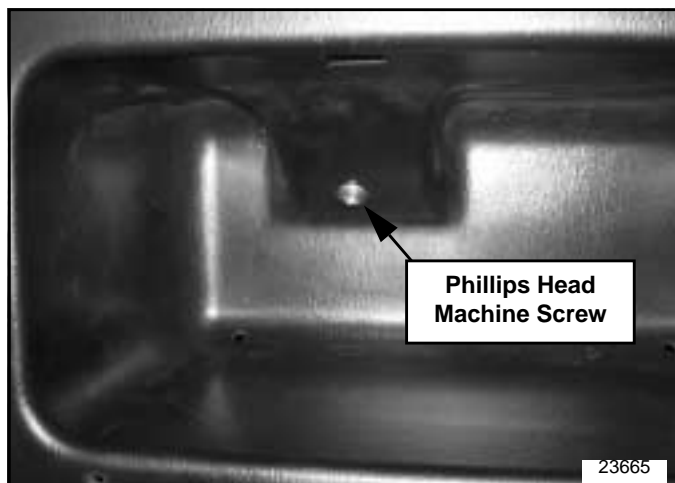

Glove Box Mounting Screw  
Figure 11

### Refer to Figure 12

16. The cup holder may be removed for cleaning by unscrewing the removable rivet until the cup holder comes loose from the dash. Reattach the cups by aligning the cup holder mounting hole with the mount hole in the dash and then pushing the rivet in place. If holes do not align, turn cup holder around.

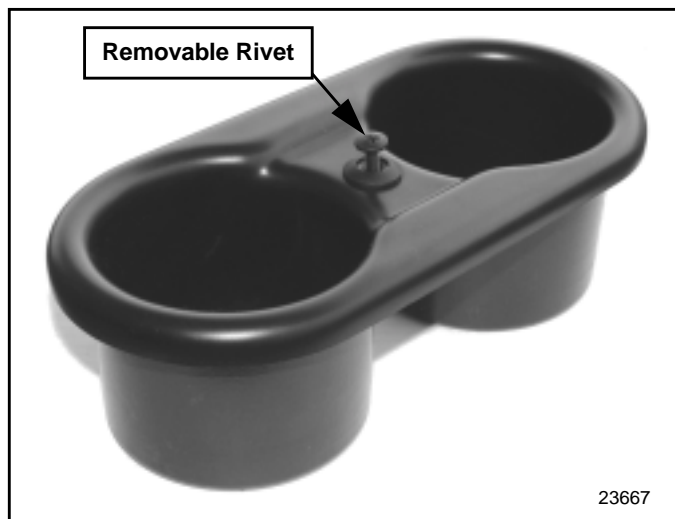

Cup Holder  
Figure 12

### Refer to Figure 13:

17. Apply new decal to the Treker as follows:

- Locate position of decal 838-491C (Warning: Improper Use) below decal 838-489C (Warning: Rollover Hazard) on the foot well.
- Clean the area the label is to be placed.
- Spray soapy water on the surface where the label is to be placed.
- Peel backing from label. Press firmly onto the surface.
- Squeeze out air bubbles with the edge of a credit card.

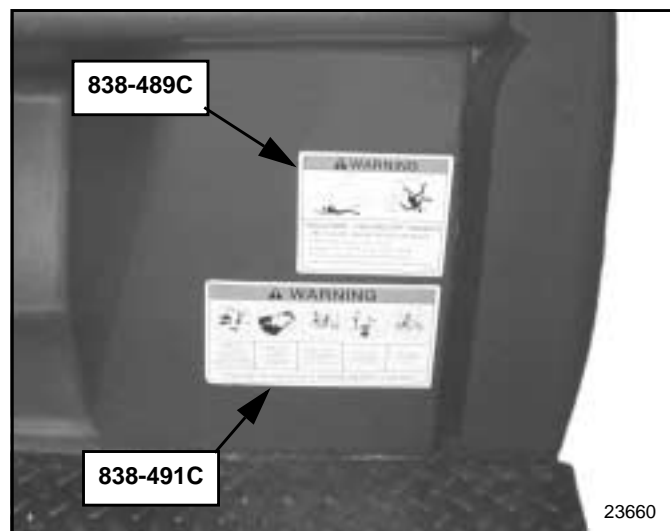

Decal 838-491C Location  
Figure 13

**Listing of Parts**

---

**Listing of Parts (For 4200ST & 4400ST Trekers)**

---

**Your kit includes:****701-013A Accessory Dash for Treker ST Series**

Qty.	Part No.	Part Description
1	700-370S	ACCESSORY DASH WITH CUP HOLDER
1	700-375M	MANUAL ACESORY DASH ST
1	700-442D	DASH MOUNT PLATE
1	800-236C	RIVET, 1/4 REMOVEABLE
1	801-180C	PHILPS HEAD MACHINE SCREW 1/4-20 x 3/4"
2	802-004C	HEX HEAD CAP SCREW 1/4-20 x 3/4" GR5
3	803-293C	NUT HEX FLANGE T-LOCK 1/4-20 PLT
2	804-117C	WASHER FLAT 1/4 HARD ASTMF436
1	833-384C	WIRE JUMPER BLACK
1	833-385C	WIRE JUMPER RED/BLACK
1	838-491C	DECAL WARNING IMPROPER USE



Corporate Office: P.O. Box 5060  
Salina, Kansas 67402-5060 USA  
[www.landpride.com](http://www.landpride.com)

---