

Shredder Kit



For RC(M)5515 & RC(M)6515 Rotary Cutters

Manual No. 330-094M

Before You Start



When you see this symbol, the subsequent instructions and warnings are serious - follow without exception. Your life and the lives of others depend on it!

IMPORTANT: Before you begin, read these instructions and check to be sure all parts and tools are accounted for. Please retain these installation instructions for future reference and parts ordering information.

Your Shredder Kit is exclusively designed for your Land Pride 55 and 65 Series Rotary Cutter. Please read these installation instructions and your Rotary Cutter Operator's Manual thoroughly before beginning. Especially read information relating to safety concerns. Also included in the Operator's Manual is important information on operation, adjustment, troubleshooting, and maintenance for this attachment (some manual sections do not apply to all accessories).

A separate Rotary Cutter Parts Manual is available free of charge at www.landpride.com or can be purchased from your nearest Land Pride dealer. Have the model and serial numbers of your cutter handy when placing an order.

Manual Part Numbers:

- Operator's Manual 318-721M
- Parts Manual 318-721P

General Information

These assembly instructions apply to the Shredder Kit listed below:

330-094A RC(M)5515 & RC(M)6515 SHREDDER KIT

NOTE: Land Pride recommends safety glasses and work gloves be worn while working on the Rotary Cutter.

Further Assistance

Your dealer wants you to be satisfied with your new Shredder Kit. If for any reason you do not understand any part of this manual or are not satisfied with the service received, the following actions are suggested:

1. Discuss the matter with your dealership service manager making sure he is aware of any problems you may have and that he has had the opportunity to assist you.
2. If you are still not satisfied, seek out the owner or general manager of the dealership, explain the problem and request assistance.
3. For further assistance write to:

Land Pride Service Department
1525 East North Street
P.O. Box 5060
Salina, Ks. 67402-5060

E-mail address
lp servicedept@landpride.com

Safety Information



WARNING

Never work under equipment supported by hydraulics. Hydraulics can drop equipment if controls are actuated or if hydraulic lines burst. Either situation can drop the cutter instantly even when power to the hydraulics is shut off.



DANGER

Always disconnect main driveline from tractor PTO before servicing the cutter deck. Cutter can be engaged if tractor is started resulting in damage to the cutter, bodily injury and/or death.

Shredder Assembly Instructions

A detailed listing of parts for this accessory kit is provided on page 4. Use the list as a checklist to inventory parts received. Please contact your local Land Pride dealer for any missing hardware.

IMPORTANT: Read "Safety Information" above before installing the shredder blades.

Refer to Figure 2 on page 2:

1. Remove all three existing blade carrier assemblies from the gearbox output shafts. Keep flat washers (D), slotted hex nuts (E) and cotter pins (F) for reuse.

Shredder Assembly Instructions

Right Wing Shredder Assembly

Refer to Figure 1:

1. Attach right wing shredder assembly (#1) to gearbox output shaft (A) with existing washer (D) and slotted hex nut (E). Torqued slotted nut to 550 ft-lbs.
2. Install cotter pin (F) in the slotted nut with legs securely bent around the nut.

Center Deck Shredder Assembly

Refer to Figure 2:

1. Attach Center Deck shredder assembly (#2) to gearbox output shaft (B) with existing washer (D) and slotted hex nut (E). Torqued slotted nut to 550 ft-lbs.
2. Install cotter pin (F) in the slotted nut with legs securely bent around the nut.

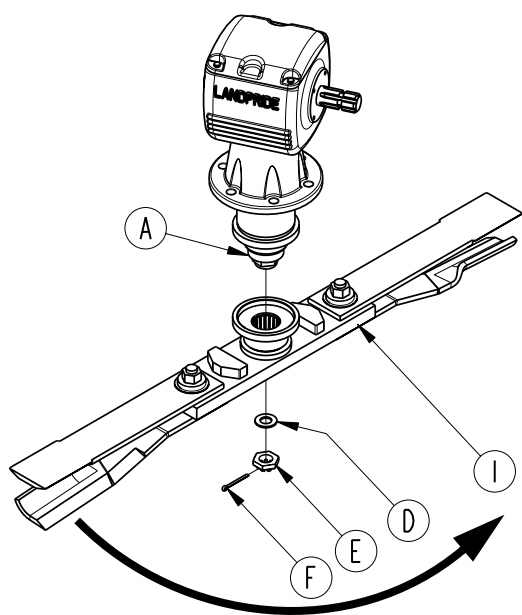

CCW Rotation
Right Wing Shredder Blades - 60" Cut

Figure 1

Left Wing Shredder Assembly

Refer to Figure 3:

1. Attach left wing shredder assembly (#3) to gearbox output shaft (C) with existing washer (D) and slotted hex nut (E). Torqued slotted nut to 550 ft-lbs.
2. Install cotter pin (F) in the slotted nut with legs securely bent around the nut.

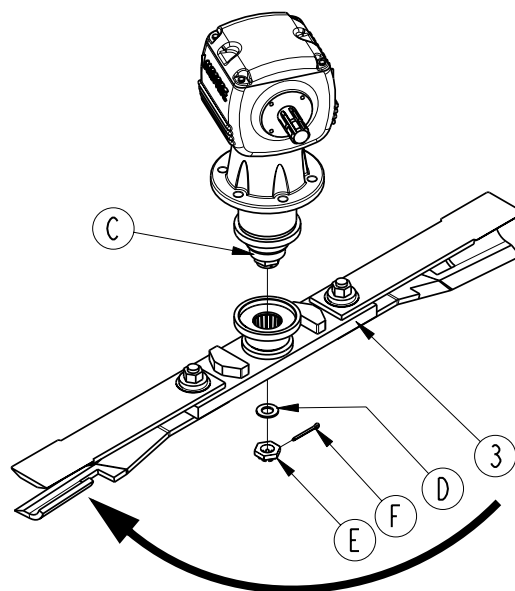

CW Rotation
Left Wing Shredder Blades - 60" cut

Figure 3

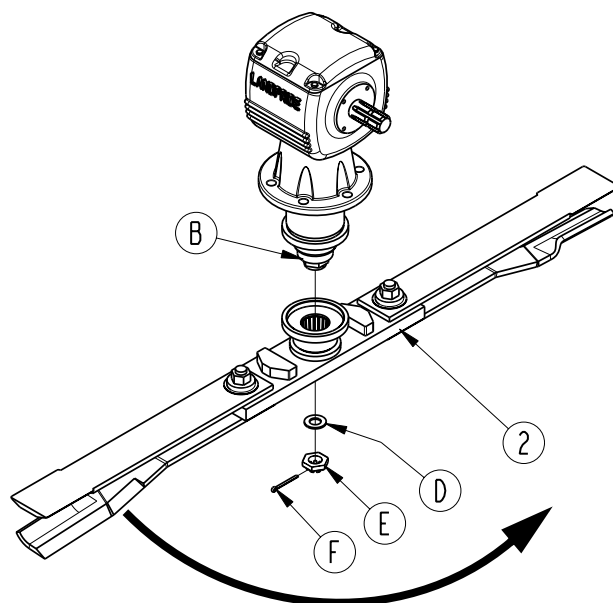

CCW Rotation
Center Deck Shredder Blades - 72" Cut

Figure 2

Shredder Assembly Instructions

Replacing Blade Spacers

Refer to Figure 4:

The cutting blades should not have more than 3/4" free vertical movement at the blade tips. If vertical movement exceeds 3/4", install or change to thicker spacers (#1) following steps 1-5.

Order spacers (#1) and locknuts (#8) from your nearest Land Pride Dealer.

IMPORTANT: Read "Safety Information" on page 1 before disassembling the shredder blades.

IMPORTANT: Locknuts can lose their ability to lock properly once removed. Always use a plain throw away nut during pre-assembly of spacers.

IMPORTANT: Spacers (#1) are not used if vertical movement at the blade tip is 3/4" or less without spacers. However, spacers are required if vertical movement at the blade tips are greater than 3/4".

1. Check blade deflection. If vertical deflection at the blade tip is greater than 3/4", remove blade bolt (#4) and reassemble using a thicker spacer (#1). Select spacer thickness based on deflection. The greater the deflection, the thicker the spacer.
2. Assemble blades by inserting 1"-8 x 4 1/2" GR8 hex head bolt (#4) through blade bushing (#2), spacer (#1), lower cutting blade (#6, #7 or #8), blade carrier (#3), upper flat cutting blade (#10 or #9), spacer (#1) and blade bushings (#2). Temporarily secure blade with a plain hex nut (Plain hex nut furnished by customer.) **Draw nut up snug. Do not tighten.**
3. Check blade vertical movement. If movement at the blade tip is greater than 3/4", remove blade bolt and reassemble as before except use a thicker spacer.
4. Once blade deflection is correct, **replace plain nut with supplied locknut (#5) & torque to 450 ft-lbs.**
5. Repeat instructions for "Replacing Blade Spacers" for the remaining shredder blade assemblies.

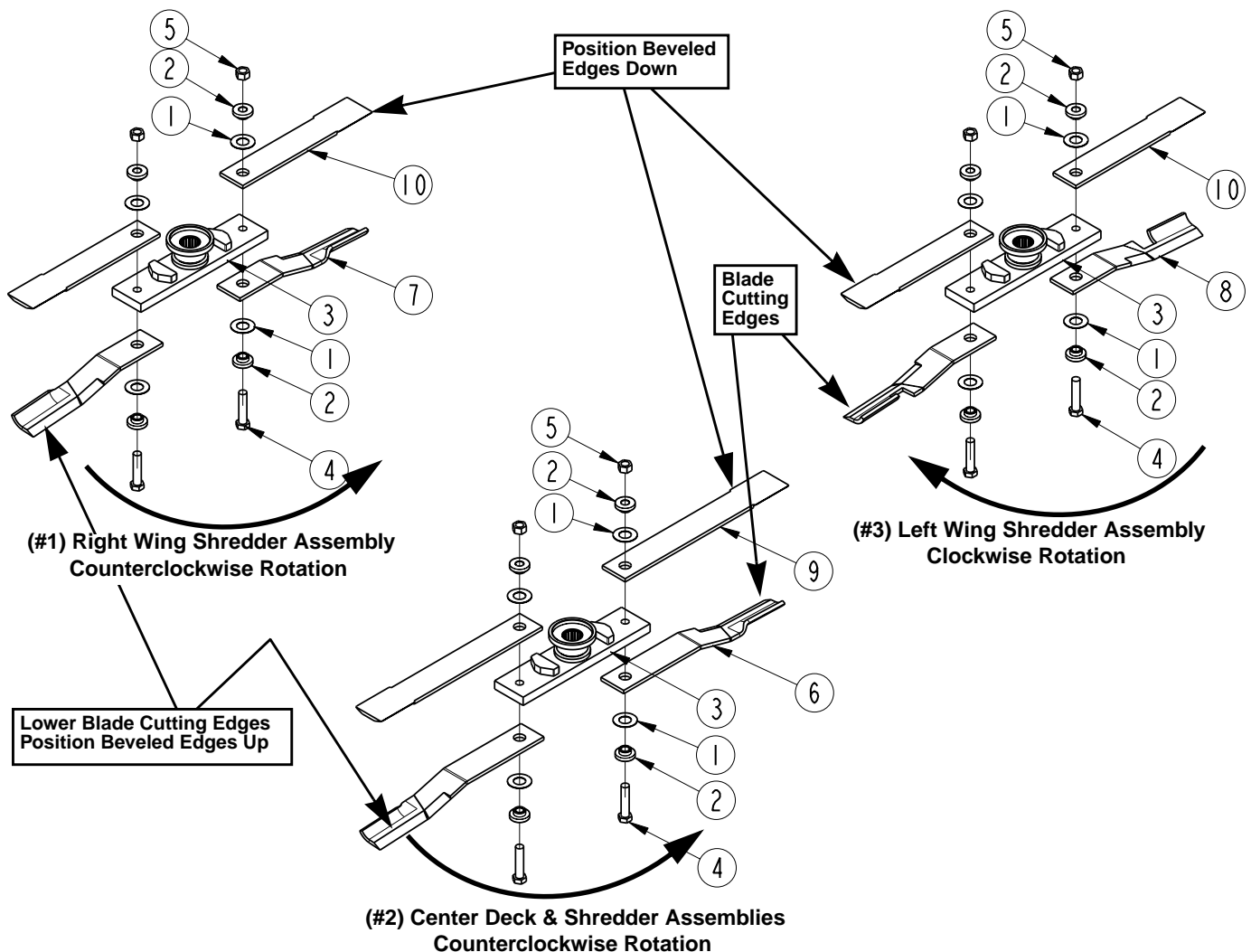

Figure 4

25603

Listing of Parts

Kit No. 330-094A RC(M)5515 & RC(M)6515 SHREDDER ASSEMBLY

Item	Qty.	Part No.	Part Description
	1	330-094M	SHREDDER KIT INSTALLATION MANUAL
1	1	330-091S	CCW BLADES, SHREDDER 60" (See Figure 1 on page 2)
2	1	330-092S	CCW BLADES, SHREDDER 72" (See Figure 2 on page 2)
3	1	330-093S	CW BLADES, SHREDDER 60" (See Figure 3 on page 2)

Refer to Figure 4 on page 3:

(#1) Components for 330-091S CCW Blade Assembly (Right Wing Shredder - 60" cut)

1	4	312-075D	BLADE SPACER 16 GA	} A maximum of four spacers are used per assembly.
1	4	312-082D	BLADE SPACER 18 GA	
1	4	312-089D	BLADE SPACER 20 GA.	
1	4	312-808D	BLADE SPACER 24GA	
2	4	318-309D	BLADE BUSHING	
3	1	330-090H	BLADE BAR, SHREDDER 5515	
4	2	802-680C	HHCS 1-8 X 4 1/2 PLT GR8	
5	2	803-168C	NUT HEX TOP LOCK 1-8 PLT	
7	2	820-169C	CUTTER BLADE 1/2X4X23 CCW	
10	4	820-217C	CUTTER BLADE 1/2X4X22.5 FLAT	

Refer to Figure 4 on page 3:

(#2) Components for 330-092S CCW Blade Assembly (Center Deck Shredder - 72" cut)

1	4	312-075D	BLADE SPACER 16 GA	} A maximum of four spacers are used per assembly.
1	4	312-082D	BLADE SPACER 18 GA	
1	4	312-089D	BLADE SPACER 20 GA.	
1	4	312-808D	BLADE SPACER 24GA	
2	4	318-309D	BLADE BUSHING	
3	1	330-090H	BLADE BAR, SHREDDER 5515	
4	2	802-680C	HHCS 1-8 X 4 1/2 PLT GR8	
5	2	803-168C	NUT HEX TOP LOCK 1-8 PLT	
6	2	820-168C	CUTTER BLADE 1/2X4X29 CCW	
9	2	820-216C	CUTTER BLADE 1/2X4X28.5 FLAT	

Refer to Figure 4 on page 3:

(#3) Components for 330-093S CW Blade Assembly (Left Wing Shredder - 60" cut)

1	4	312-075D	BLADE SPACER 16 GA	} A maximum of four spacers are used per assembly.
1	4	312-082D	BLADE SPACER 18 GA	
1	4	312-089D	BLADE SPACER 20 GA.	
1	4	312-808D	BLADE SPACER 24GA	
2	4	318-309D	BLADE BUSHING	
3	1	330-090H	BLADE BAR, SHREDDER 5515	
4	2	802-680C	HHCS 1-8 X 4 1/2 PLT GR8	
5	2	803-168C	NUT HEX TOP LOCK 1-8 PLT	
8	2	820-170C	CUTTER BLADE 1/2X4X23 CW	
10	4	820-217C	CUTTER BLADE 1/2X4X22.5 FLAT	



Corporate Office: P.O. Box 5060
Salina, Kansas 67402-5060 USA
www.landpride.com