

Assembly Instructions



PS25120 Primary Seeder Walkboard Option

Used with:

- PS25120 Primary Seeder



When you see this symbol, the subsequent instructions and warnings are serious - follow without exception. Your life and the lives of others depend on it!

Before You Start

These option assembly instructions contain only information on assembling the attachment to the main unit. A detailed Operator's Manual was supplied with the main unit when it was purchased. For more specific information on safety concerns refer to the Operator's Manual. Also included in the Operator's Manual is important information on operation, adjustment, troubleshooting, and maintenance for this attachment (some of these sections do not apply to all options).

A separate Parts Manual for replacement parts can be purchased from your dealer. Have model and serial numbers handy when placing an order.

Manual Part Numbers:

- PS25120 Primary Seeder Operator's Manual313-156M
- PS25120 Primary Seeder Parts Manual 313-156P

General Information

These option assembly instructions apply to the Walkboard Option listed below:

313-130A PS25120 Walkboard Bundle

Starting on page 4 is a detailed listing of parts included in this kit. Use this list as a checklist to inventory parts received.

Assembly Instructions

1. Mark and drill two 17/32" holes each on the left and right hand frame end plates as shown in Figure 1.

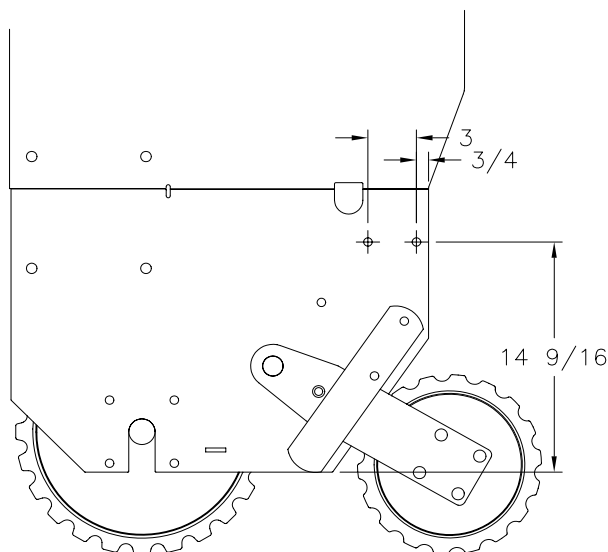
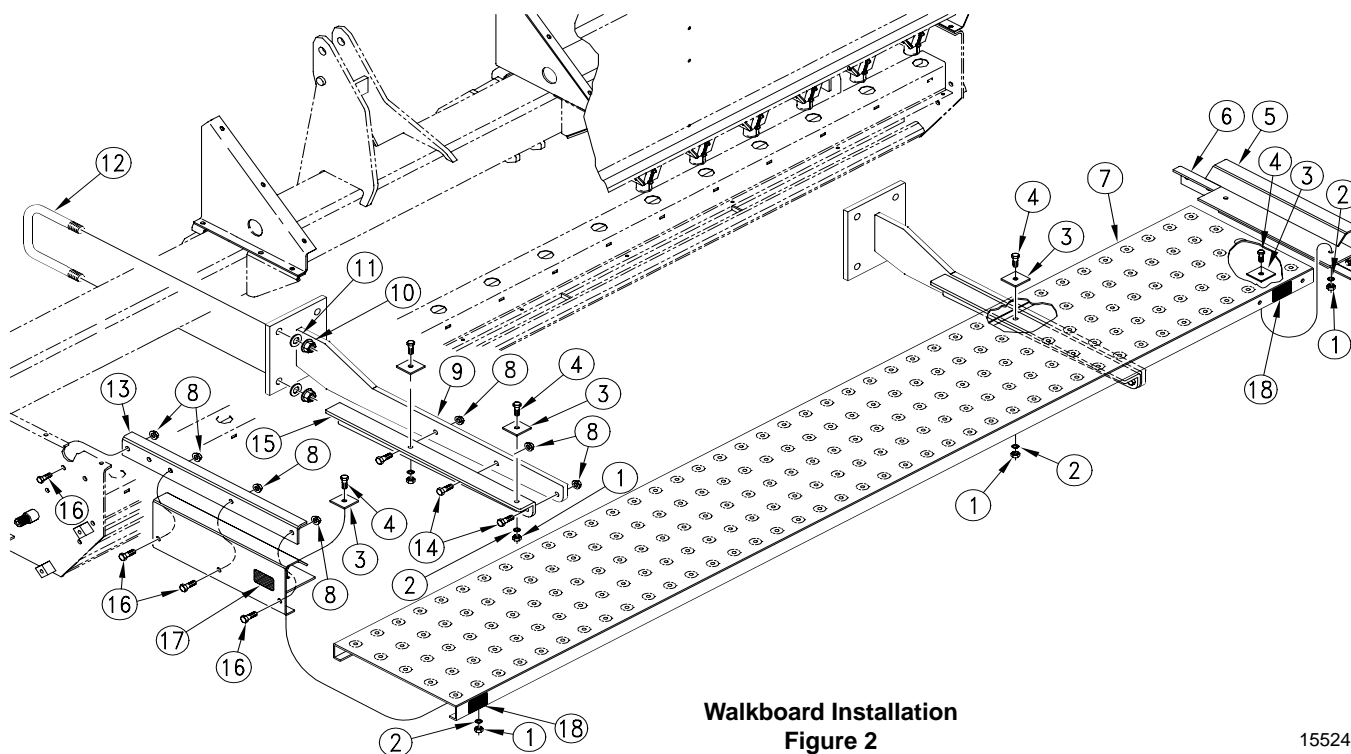

Figure 1

13267

Refer to Figure 2:

2. Install Left and Right End Mounts (#1) and (#2) using two 1/2" x 1 1/4" long flange bolts (#3) and two 1/2" flange nuts (#4) on each mount.
3. Attach an End Support (#5) to each End Mount using three 1/2" x 1 1/4" long bolts (#3) and three 1/2" flange nuts (#4) on each support. See Figure 3 for mounting hole locations.



Walkboard Installation
Figure 2

15524

Assembly Instructions

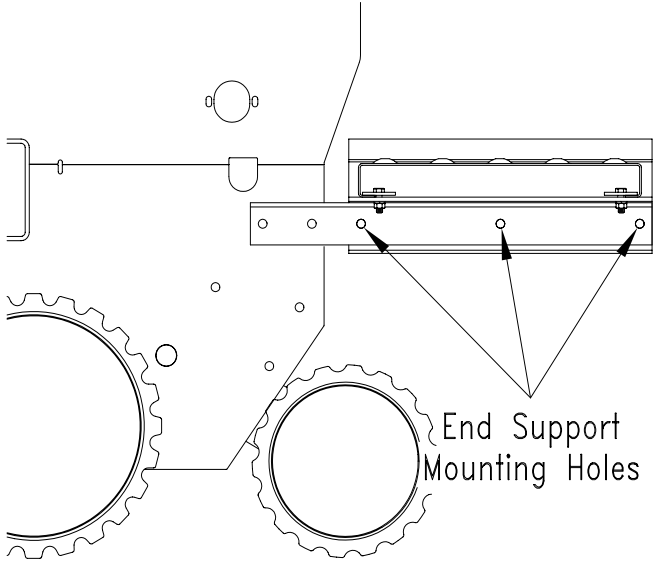

Figure 3 13268

- 5. Attach Center Supports (#10) to each Center Mount using three 1/2" x 1 3/4" long hex bolts (#11) and three 1/2" flange nuts (#4) for each support. See Figure 4 for mounting hole locations.

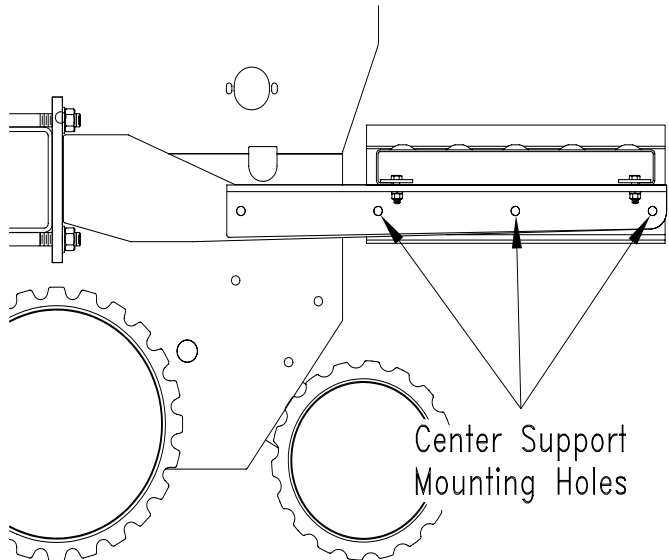

Figure 4 13270

- 4. Install Center Mounts (#6) at approximately the locations shown in Figure 5 using two u-bolts (#7), 3/4" washers (#8) and 3/4" flange nuts (#9) on each support.

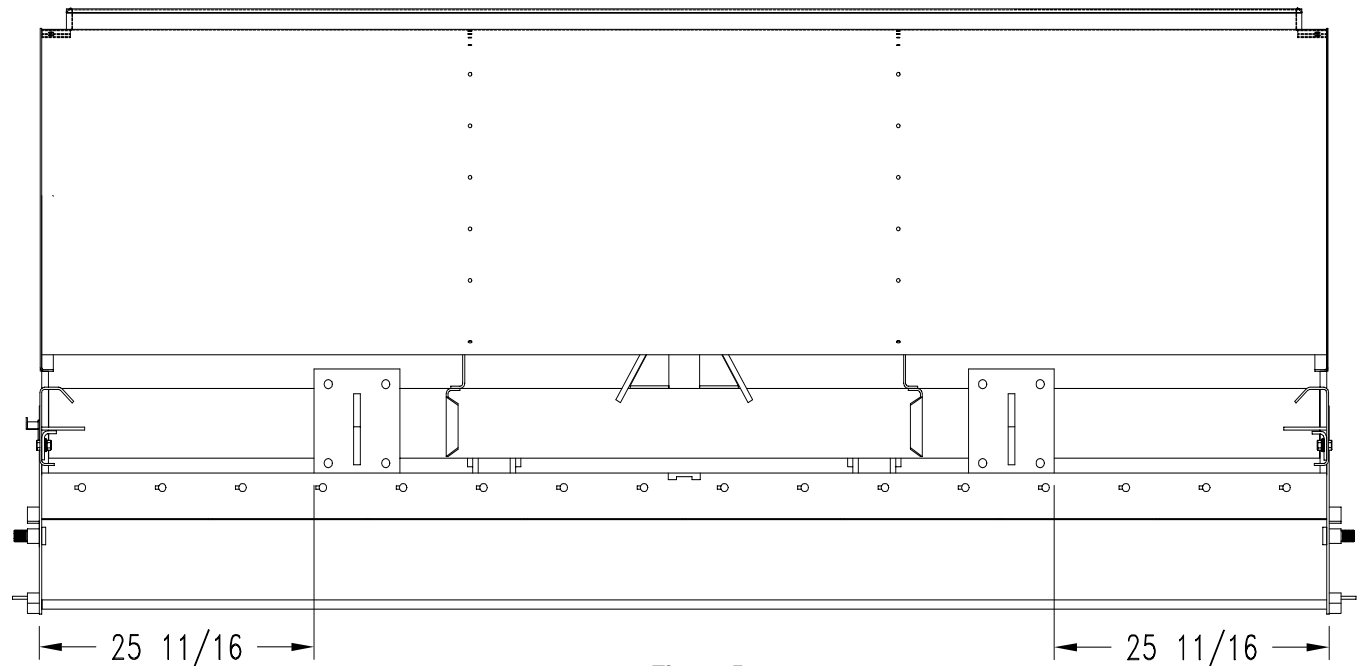

Figure 5 13269

Assembly Instructions

6. Position Walkboard (#12) on supports and secure with retainers (#13), 3/8" x 1 1/4" long hex bolts (14), 3/8" lock washers (#15) and 3/8" nuts (#16). Refer also to Figure 6.

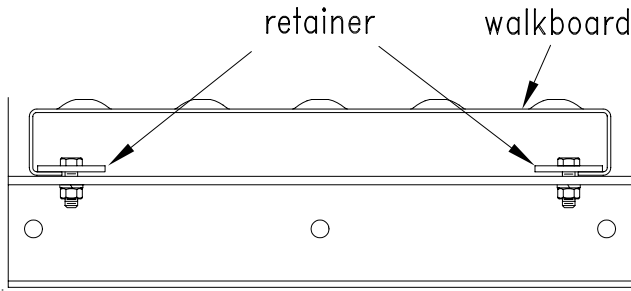

Figure 6

13271

7. Install amber reflector (#17) and red reflector (#18). See the safety section in your Operator's Manual for correct installation of decals.

Installation with Small Seeds Box Attachment

For seeders with a Small Seeds Box Attachment, install using the previous instructions but for step 3 see Figure 7 and for step 5 see Figure 8.

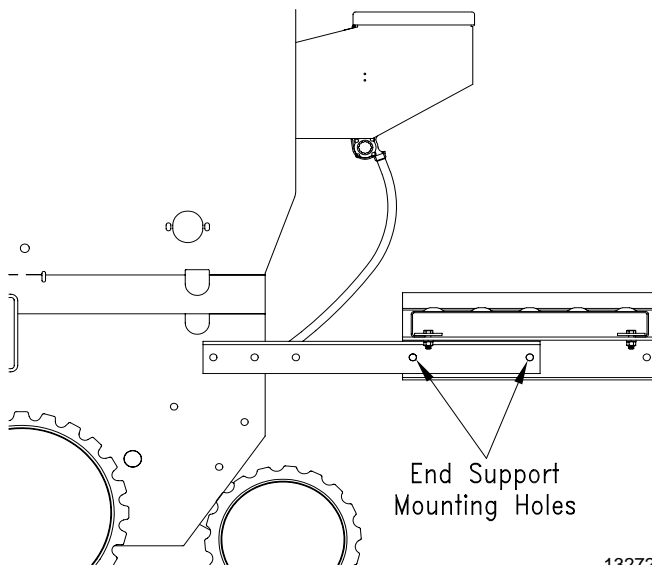

Figure 7

13272

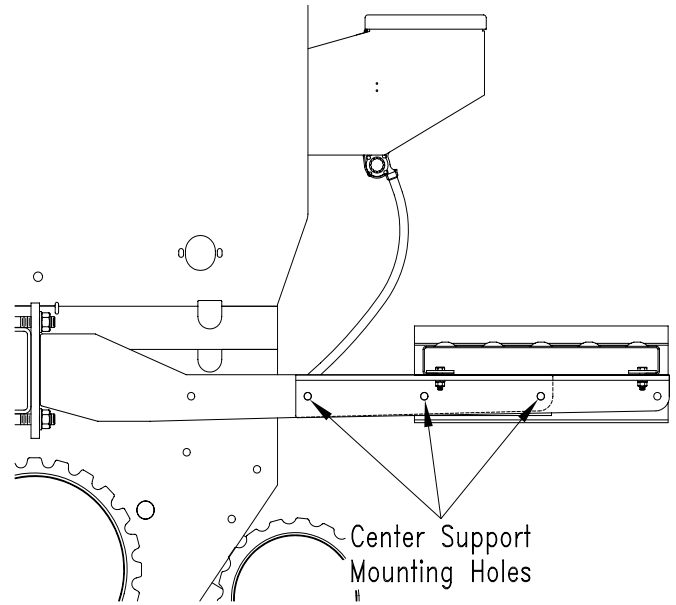

Figure 8

13273

Listing of Parts

313-130A PS25120 Walkboard Bundle

Your Kit Includes:

Qty.	Part No.	Part Description
8	119-032D	3-PT STEP RETAINER
1	119-156D	WALKBOARD 3PT 20'
2	313-128H	WALKBOARD END SUPPORT WELDMENT
2	313-129H	WALKBOARD CENTER MOUNT WELDMNT
1	313-272D	WALKBOARD LEFT END MOUNT
1	313-273D	WALKBOARD RIGHT END MOUNT
2	313-276D	WALKBOARD CENTER SUPPORT
10	802-034C	HHCS 1/2-13X1 1/4 GR5
8	802-079C	HHCS 3/8-16X1 1/4 GR5
6	802-082C	HHCS 1/2-13X1 3/4 GR5
8	803-014C	NUT HEX 3/8-16 PLT
16	803-169C	NUT HEX FLG. LOCK 1/2-13 PLT.
8	803-214C	NUT HEX FLANGE 3/4-10 PLT
8	804-013C	WASHER LOCK SPRING 3/8 PLT
8	804-093C	WASHER 3/4 HARDENED STEEL
4	806-093C	U-BOLT 3/4-10 6 1/32 X 7 3/4
2	818-229C	DECAL AMBER REFLECTOR
2	818-335C	DECAL RED NARROW REFLECTOR
1	313-130A	PS25120 WALKBOARD BUNDLE