

**Pallet Forks**

**PF10 & PF20 Series**

Description	Model PF10	Model PF20
Lift Capacity Per Set of 2 Pallet Forks	1,000 lbs.	2,000 lbs.
Tine Length	31 5/8"	35 5/8"
Weight Each	55 lbs.	65 lbs.
Tine Width	3"	
Tine Height	2"	
Threaded Clamp Rod	1 1/4" - 7"	
Throat Opening	1 1/2"	
Throat Depth	10 3/4"	
Sliding Clamp Handles	9" Arm Length (Center of screw to end of arm)	

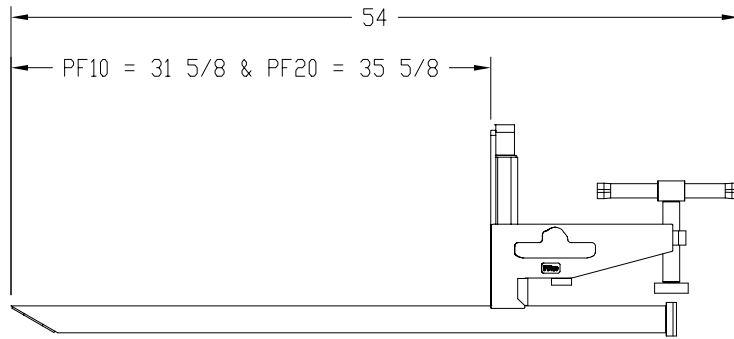
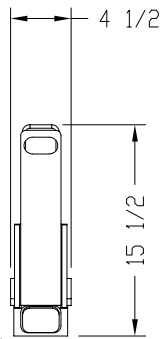

26759

*Designs, specifications, features and information are subject to change without notice.*