

**Post Hole Diggers, Hydraulic Drive**

**SAC35 Model (Skid Steer)**

<b>SAC35</b>			
<b>Gallons Per Minute Rating</b>	10 - 25 GPM @ 1500 to 3500 PSI		
<b>Weight without Auger</b>	365 lbs.		
<b>Auger Length</b>	48"		
<b>Auger Flighting Thickness</b>	5/16"		
<b>Auger Pipe</b>	2 1/2" ID		
<b>Auger Teeth</b>	Forged, Individually Replaceable 40 Degree angle installed on flat side 50 Degree angle installed on angled side		
<b>Number of Teeth</b>	<table border="0" style="width: 100%;"> <tr> <td style="width: 50%; vertical-align: top;"> <b>Standard Augers</b>                      9" &amp; 12" - 4 teeth                      15" - 5 teeth                      18" - 6 teeth                      24" - 8 teeth                      30" - 10 teeth                      36" - 12 teeth                 </td> <td style="width: 50%; vertical-align: top;"> <b>Tree Augers</b>                      24" - 9 teeth                      30" - 11 teeth                      36" - 13 teeth                 </td> </tr> </table>	<b>Standard Augers</b> 9" & 12" - 4 teeth 15" - 5 teeth 18" - 6 teeth 24" - 8 teeth 30" - 10 teeth 36" - 12 teeth	<b>Tree Augers</b> 24" - 9 teeth 30" - 11 teeth 36" - 13 teeth
<b>Standard Augers</b> 9" & 12" - 4 teeth 15" - 5 teeth 18" - 6 teeth 24" - 8 teeth 30" - 10 teeth 36" - 12 teeth	<b>Tree Augers</b> 24" - 9 teeth 30" - 11 teeth 36" - 13 teeth		
<b>Pilot</b>	Cast Steel, 3 -Drill Points		
<b>Auger Drive</b>	Sprocket & #60 Roller Chain		
<b>Hydraulic Motor Rating</b>	18 GPM (Gallons Per Minute)		
<b>Output Shaft</b>	2" Hex or 2 9/16" OD round		
<b>Hitch</b>	Skid Steer Mounting Plate		
<b>Options and Accessories</b>			
<b>Auger Sizes (Options)</b>	9", 12", 15", 18", 24", 30" and 36"		
<b>Auger Extensions (Accessories)</b>	<table border="0" style="width: 100%;"> <tr> <td style="width: 50%;">2" Hex extension: 24" &amp; 48" Extensions Available</td> <td style="width: 50%;">2 9/16" OD round extension: 24" &amp; 48" Extensions Available</td> </tr> </table>	2" Hex extension: 24" & 48" Extensions Available	2 9/16" OD round extension: 24" & 48" Extensions Available
2" Hex extension: 24" & 48" Extensions Available	2 9/16" OD round extension: 24" & 48" Extensions Available		

*Designs, specifications, features and information are subject to change without notice.*

# Specifications & Capacities

## Post Hole Diggers, Hydraulic Drive

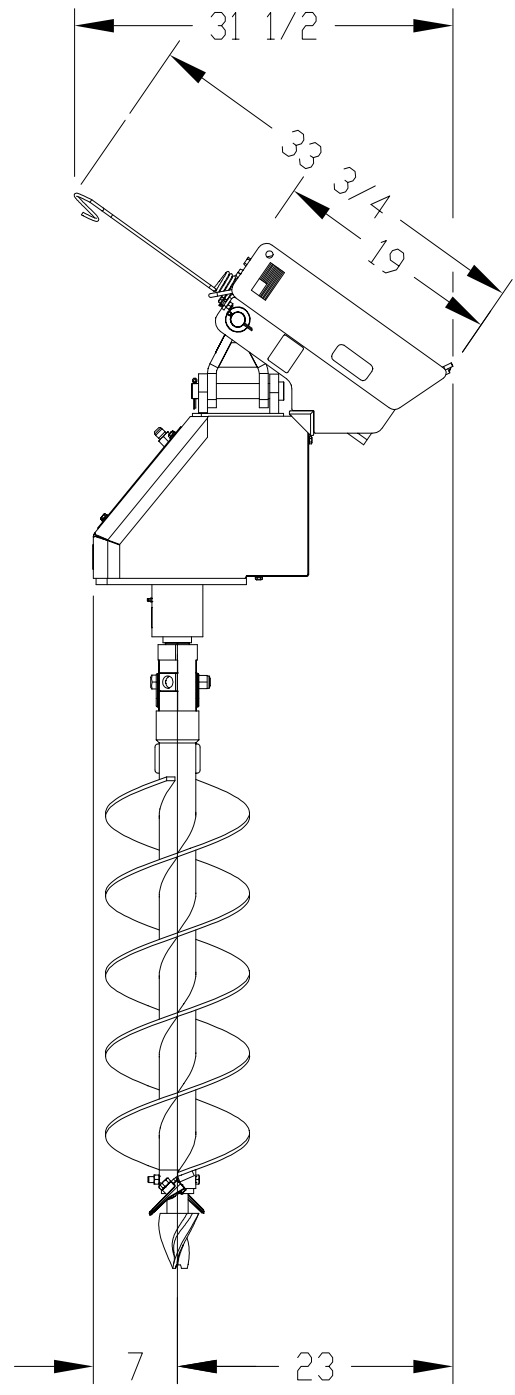
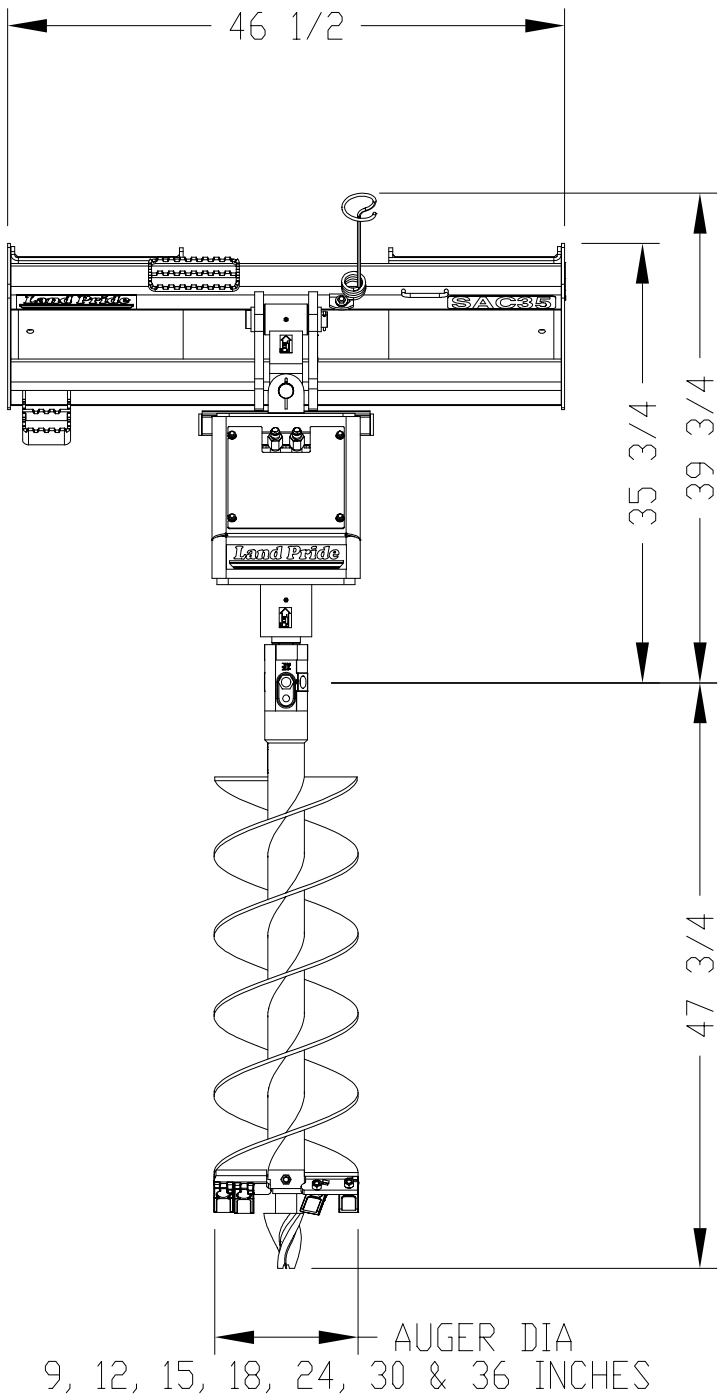

Designs, specifications, features and information are subject to change without notice.