

Post Hole Diggers, Hydraulic Drive

SA35 Model (Skid Steer)																									
SA35																									
Skid Steer Hydraulic	10 - 25 GPM @ 1500 to 3500 PSI																								
Weight without Auger	435 lbs.																								
Auger Length	9" Auger size = 46" All other auger sizes = 48"																								
Auger Flighting Thickness	5/16"																								
Auger Pipe	2 1/2" ID																								
Auger Teeth	Forged, Individually Replaceable 40 Degree angle installed on flat side 50 Degree angle installed on angled side																								
Number of Teeth	<table border="0" style="width: 100%;"> <tr> <td style="width: 50%;">Standard Augers</td> <td style="width: 25%;">9" & 12" - 4 teeth</td> <td style="width: 20%;">Tree Augers</td> <td style="width: 5%;">24" - 9 teeth</td> </tr> <tr> <td></td> <td>15" - 5 teeth</td> <td></td> <td>30" - 11 teeth</td> </tr> <tr> <td></td> <td>18" - 6 teeth</td> <td></td> <td>36" - 13 teeth</td> </tr> <tr> <td></td> <td>24" - 8 teeth</td> <td></td> <td></td> </tr> <tr> <td></td> <td>30" - 10 teeth</td> <td></td> <td></td> </tr> <tr> <td></td> <td>36" - 12 teeth</td> <td></td> <td></td> </tr> </table>	Standard Augers	9" & 12" - 4 teeth	Tree Augers	24" - 9 teeth		15" - 5 teeth		30" - 11 teeth		18" - 6 teeth		36" - 13 teeth		24" - 8 teeth				30" - 10 teeth				36" - 12 teeth		
Standard Augers	9" & 12" - 4 teeth	Tree Augers	24" - 9 teeth																						
	15" - 5 teeth		30" - 11 teeth																						
	18" - 6 teeth		36" - 13 teeth																						
	24" - 8 teeth																								
	30" - 10 teeth																								
	36" - 12 teeth																								
Pilot	Cast Steel, 3 -Drill Points																								
Auger Drive	Hydraulic																								
Gearbox	18 GPM (Gallons Per Minute) Hydraulically driven planetary gearbox; reversible																								
Output Shaft	2" Hex or 2 9/16" O.D. round																								
Hitch	Skid Steer Mounting Plate																								
Options and Accessories																									
Auger sizes (Options).	Standard: 9", 12", 15", 18", 24", 30" and 36" / Tree: 24", 30" and 36"																								
Gearbox Output Shafts (Options)	2" Hex or 2 9/16" OD round																								
Auger Extensions (Accessories)	<table border="0" style="width: 100%;"> <tr> <td style="width: 50%;">2" Hex extension: 24" & 48" Extensions Available</td> <td style="width: 50%;">2 9/16" OD round extension: 24" & 48" Extensions Available</td> </tr> </table>	2" Hex extension: 24" & 48" Extensions Available	2 9/16" OD round extension: 24" & 48" Extensions Available																						
2" Hex extension: 24" & 48" Extensions Available	2 9/16" OD round extension: 24" & 48" Extensions Available																								

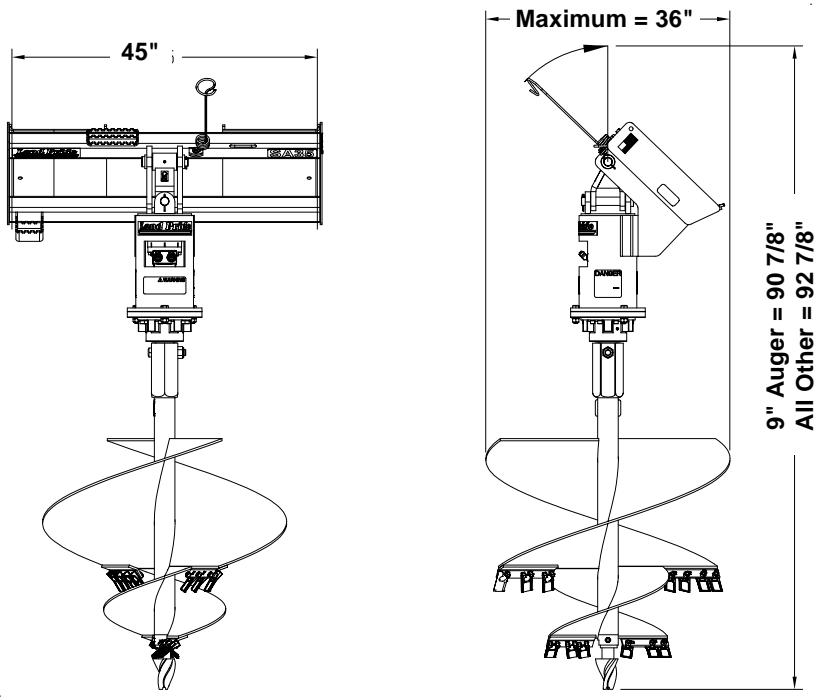

26782

Designs, specifications, features and information are subject to change without notice.