

Post Hole Diggers Hydraulic Drive

HD25 and HD35 Models				
	HD25 (3-Point)	HD25 (Bucket Mount)	HD35 (3- Point)	HD35 (Bucket Mount)
Hydraulic Hoses	Standard	Optional	Standard	Optional
Maximum Auger RPM	109 RPM	105 RPM	109 RPM	105 RPM
Gallons Per Minute Rating	5 -12 GPM @ 1500 to 3000 PSI		10 -25 GPM @ 1500 to 3000 PSI	
Max torque @ 2500 PSI	700 ft. lbs.		1605 ft. lbs.	
Weight with 6" Auger	235 lbs.	185 lbs.	235 lbs.	189 lbs.
Auger Length	48"			
Auger Flighting Thickness	1/4"			
Auger Pipe	2 1/2" dia.			
Auger Teeth	Forged, Individually Replaceable 40 Degree Angle Installed on Flat Side 50 Degree Angle Installed on Angled Side			
Number of Teeth	(6" - 2 teeth) (9" & 12" - 4 teeth) (15" - 5 teeth) (18" - 6 teeth) (24" - 8 teeth)			
Pilot	Cast steel, 3 drill points			
Auger Drive	Hydraulic			
Gearbox	3.18:1 Ratio			
Gearbox oil capacity & Type	4.7 Pints of Gear Lube 80-90W EP			
Output Shaft on Gearbox	2" O.D. Round			
Hitch	Cat I or II	Bucket Mount	Cat I or II	Bucket Mount
Yoke	2 7/8" Tubing	Not Applicable	2 7/8" Tubing	Not Applicable
Boom	Reinforced Tubing	Not Applicable	Reinforced Tubing	Not Applicable
Options and Accessories				
Auger Sizes	6", 9", 12", 15", 18" or 24"			
Hydraulic Hoses	Not Applicable	(2)-24 ft. long hoses	Not Applicable	(2)-24 ft. long hoses
Hydraulic Down Pressure Kit	Available	Not Applicable	Available	Not Applicable
Storage Stand	Available	Not Applicable	Available	Not Applicable
Auger Extensions	7" and 14" Extensions Available			

Designs, specifications, features and information are subject to change without notice.

Specifications & Capacities

Post Hole Diggers Hydraulic Drive

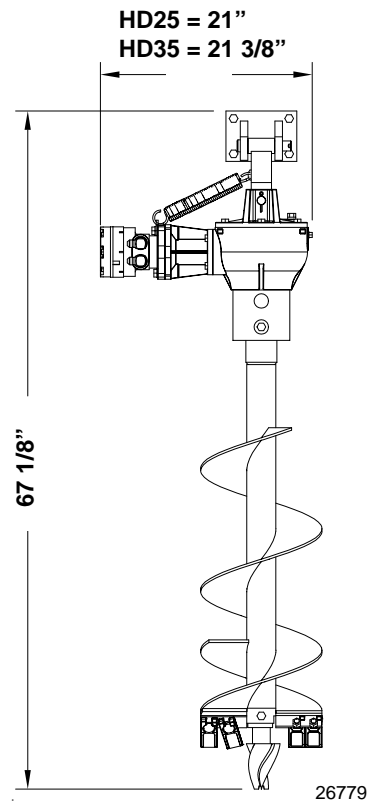
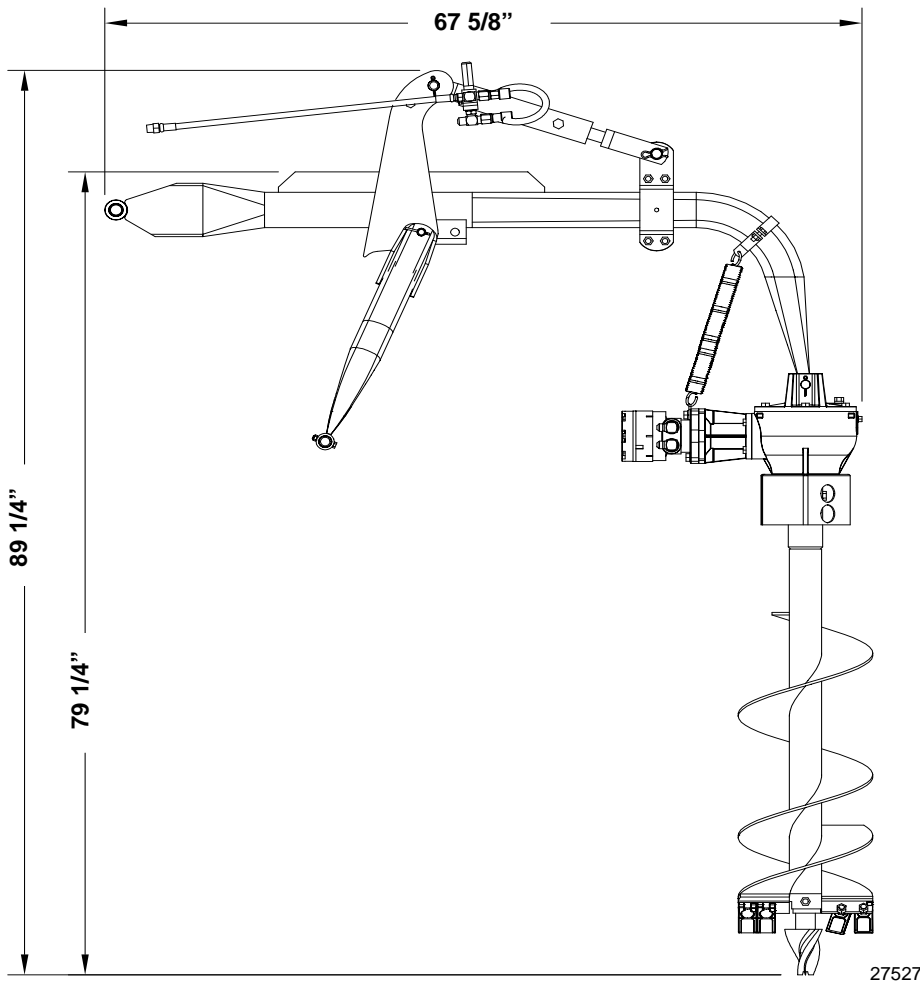
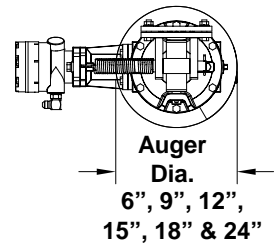
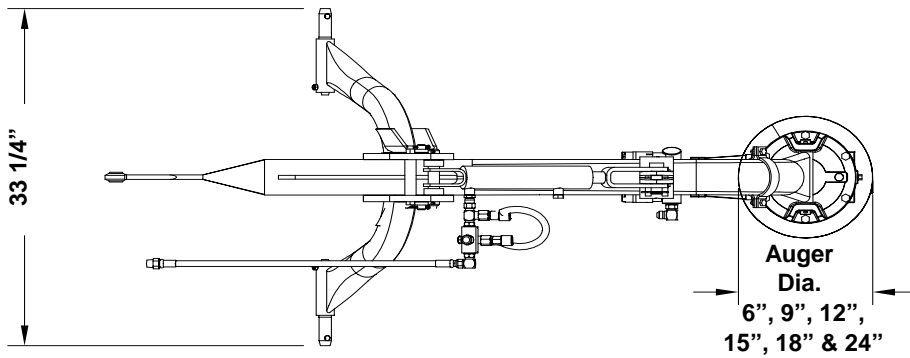

3-Point Mount Post Hole Digger

Bucket Mount Post Hole Digger

Designs, specifications, features and information are subject to change without notice.