

Hydraulic Reservoir System

HRS Series

Description		Model HRS18	Model HRS23
Minimum Tractor Horsepower		28 HP	32 HP
Pump Capacity		Approx. 17 GPM @ 540 RPM	Approx. 21 GPM @ 540 RPM
PTO Input Speed		540 RPM	
Hydraulic Fluid Type		Mobil Fluid 424 (See www.mobil.com for alternate fluids)	
Reservoir Capacity		35 Gallons	
Filter Type		Conventional 10 Micron Filter	
Oil Level Check		Oil fill cap with dipstick	
Overload Protection		Hydraulic relief valve	
Hitch		3-Point Cat. I & II with clevis style lower hitch, Quick Hitch adaptable	
Reservoir Capacity and		35 Gallons	
Filter Type		Conventional 10 Micron Filter	
Overload Protection		2000 PSI hydraulic relief valve	
Driveline		ASAE Category 2	
Pressure & Return Hose Lengths		24 Feet each	
Case Drain Port		3/4"-16 UNF	
Optional & Accessory Equipment			
Flow Control	Option #1	No valve Option (Pressure relief valve provided for protection.)	
	Option #2	Hand Operated Valve (Pressure relief is built into the valve)	
	Option #3	Solenoid Operated Valve (Pressure relief is built into the valve)	
Pump Arrangement	Option #1	Tractor PTO Mounted Pump	
	Option #2	Driveline Connected Pump	
Oil Cooler Accessory	Option #1	Oil Cooler with electrical controls (Use with no valve option & hand valve option)	
	Option #2	Oil Cooler without electrical controls (Use with solenoid valve option)	

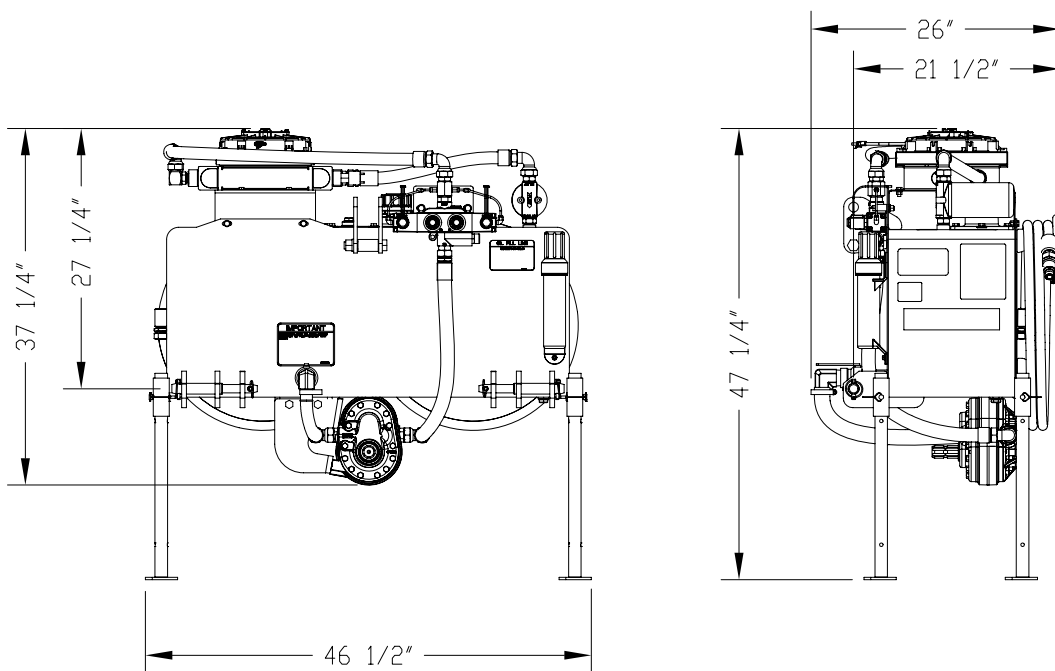

Designs, specifications, features and information are subject to change without notice.