

**All Flex Mowers**

**AFM4216 Model**

Description	Specification / Capacity	Description	Specification / Capacity
Discharge Type	Rear	Cutting Height	3/4" to 5 1/4" (In 1/4" increments)
Cutting Width	16'- 8"	Blade Drive Belt	1 B-Section
Overall Width	16' -10"	Drive Belt Tension	Spring Loaded Idler with Overcenter Release
Transport Height	8' -10"	Blade Bearing	Sealed Ball Bearings
Transport Width	6'- 8" With Lock Pins Installed	Blade Overlap	1 1/4"
Overall Length	15'-0" Mowing Position 13'-4" Transport Position	Blades 3 Each Per Deck	Low Lift (5/16" x 2 1/2" x 25") Optional Blades: Medium Lift, High Lift & Mulching
Machine Weight	W/15" tires = 3,315 lbs. W/18" tires = 3,465 lbs.	Blade Spindle Speed	2,302 R.P.M.
Tractor Horsepower	Minimum 40 HP / Maximum 70 HP	Blade Tip Speed	18,340 F.P.M.
Hitch	Pull Type with Adjustable Clevis and Safety Tow Chain	Deck Tires	10 each, Air tires with Sealant 18 x 9.5 or 15 x 6.6
Tongue Support	2,200 lb. Capacity Screw Jack	Deck Wheel Spindles	1 1/4" w/Nylon Bushings
Gearbox Support	3/8" Steel Channel	Transport Tires	2 each, 23 x 10.5 with Sealant
Gearboxes	540 RPM (1)-Splitter & (3)-Wing	Transport Locks	Automatic with Pull Rope Release
Gearbox Lubrication	Gear Lube 80-90W EP	Turning Radius	Zero Turning Radius
Gearbox Oil Capacity	3 - Wings: 3.5 Pints SD Splitter: 2.125 Pints or OMNI Splitter: 2.5 Pints	Mowing Capacity	@ 2 mph = 4.0 Acres Per Hour @ 4 mph = 8.1 Acres Per Hour @ 6 mph = 12.1 Acres Per Hour
Anti-Scalp Roller	Front Center and Outside Deck Corners	Wing Deck Flex	23 Degrees Left To Right 22 Degrees Front To Back
Main Driveline (1)	Cat. IV Constant Velocity with Slip Clutch	Center Deck Flex	10 Degrees Left To Right 22 Degrees Front To Back
Deck Drivelines (3)	Cat. II	Hydraulic Outlets	1 Set Required
Deck Size & Quantity	3 each / 72"	Deck Cylinders	Dual Acting
Deck Overlap	8"	Gauge Wheel Arms	1/4" Wall Square Tubing
Deck Thickness	3/16"		

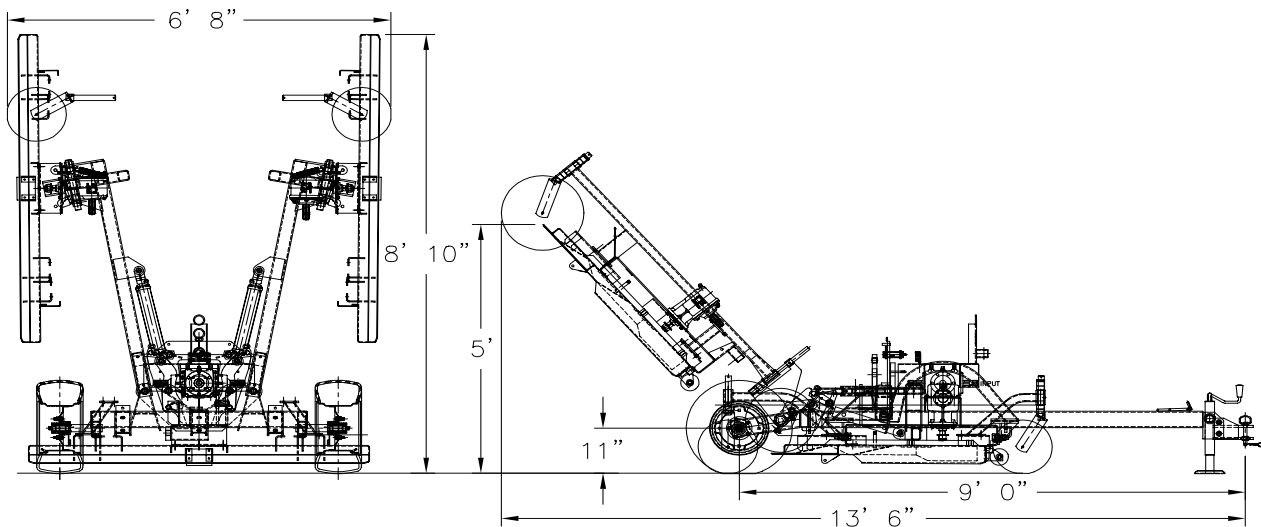

**Model 4216 Specification Drawing**

*Designs, specifications, features and information are subject to change without notice.*

17853

All Flex Mowers

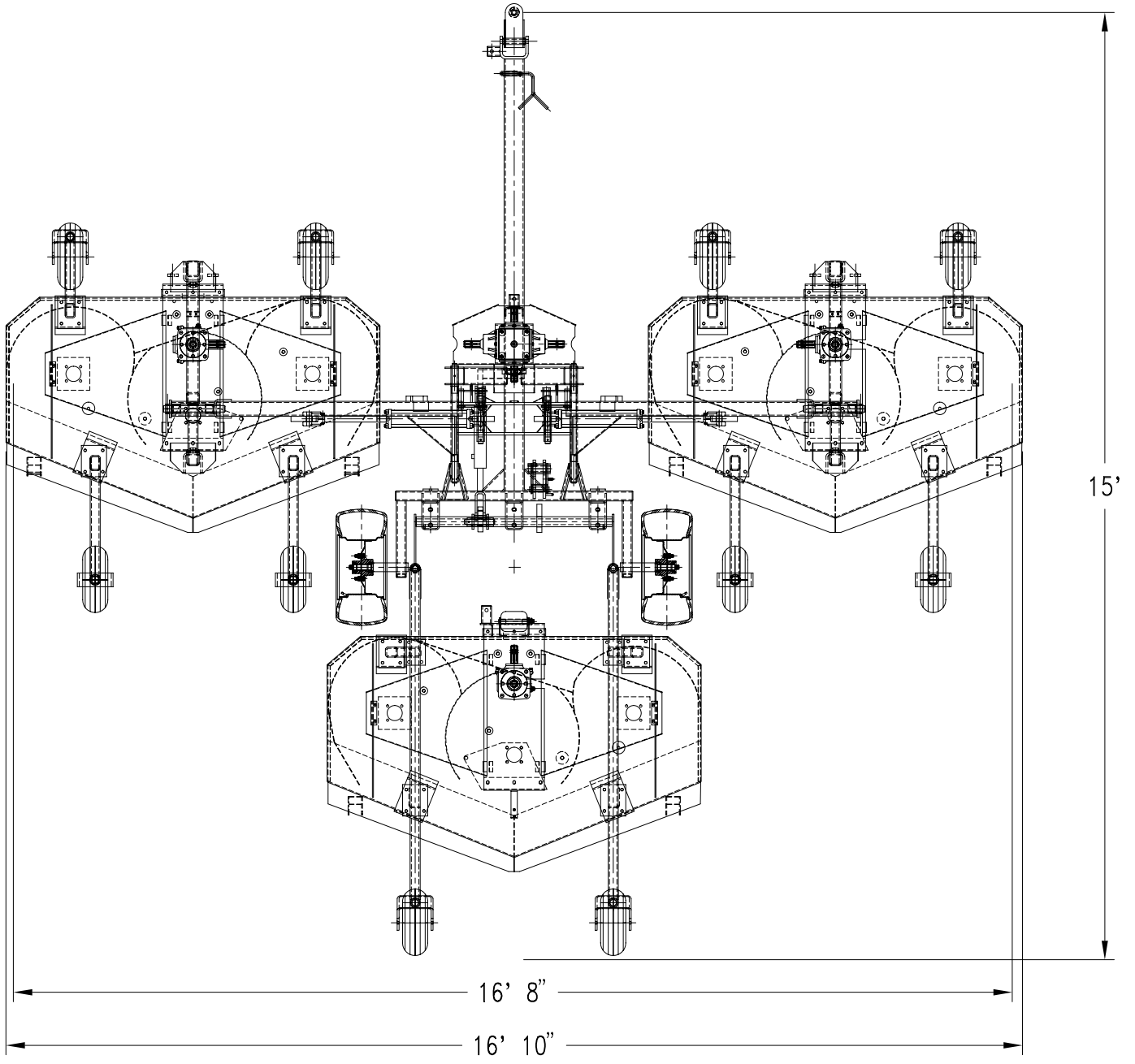

Model 4216 Specification Drawing

13665

Designs, specifications, features and information are subject to change without notice.