

Rotary Cutters Single Deck

RCR2660 & RCR2672 Models		
	RCR2660	RCR2672
Machine Weight (with Chain Guards)	1,002#	1,046#
Hitch	Category I or II Quick Hitch Compatible with Floating Top Link	
Cutting Width	60"	72"
Overall Width	67"	79"
Overall Length (Including Tailwheel)	114"	126"
Deck Height	9 1/8" (Bottom of Deck to Bottom of Skid Shoe)	
Cutting Height	2" - 12"	
Cutting Capacity	3"	
Recommended Tractor HP	40-130 maximum	
PTO Speed	540 rpm	
Gearbox	540 rpm PTO Driven Gearbox 1:1.46 Speed-Up Beveled Gears Cast Iron Housing	
Gearbox Lubrication Capacity & Type	7 pints of 80-90W EP oil	
Gear box Input/ Output Shaft Size	Input Shaft = 1 3/8" - 6 Spline Output Shaft = 2" Dia.	
Deck Construction	All welded construction	
Deck Material Thickness	10 Gauge	
Side Panel Thickness	1/4"	
Skids	Replaceable	
Stump Jumper	Round Pan 3/16" x 25"	Round Pan 3/16" x 32"
Blades (2)	1/2" x 4" x 25" Heat Treated Alloy Steel Free-Swinging High Lift	1/2" x 4" x 29" Heat Treated Alloy Steel Free-Swinging High Lift
Blade Bolt	Keyed with harden flat washer and lock nut	
Blade Tip Speed	12,384 fpm/788 rpm	14,861 fpm/788rpm
Driveline	ASAE Category 4	
Driveline Protection	4 Plate Slip Clutch	
Tailwheel Mount Assembly	Welded arm and Caster Fork	
Tailwheel	4.00 x 8 x 15 Laminated Tire with cast iron hub and tapered roller bearings	
Front Guard	Optional: Chain Guard Available through Parts Department: Rubber Guard	
Rear Guard	Optional: Chain Guard	

Designs, specifications, features and information are subject to change without notice.

Specifications & Capacities

Rotary Cutters Single Deck

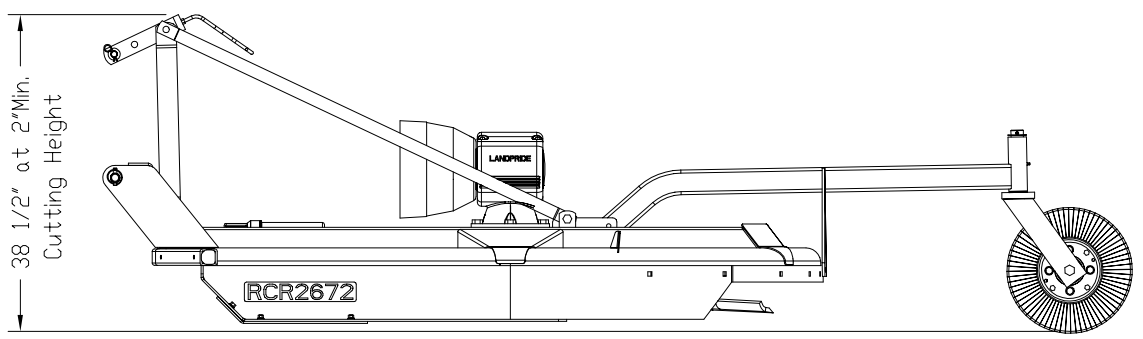
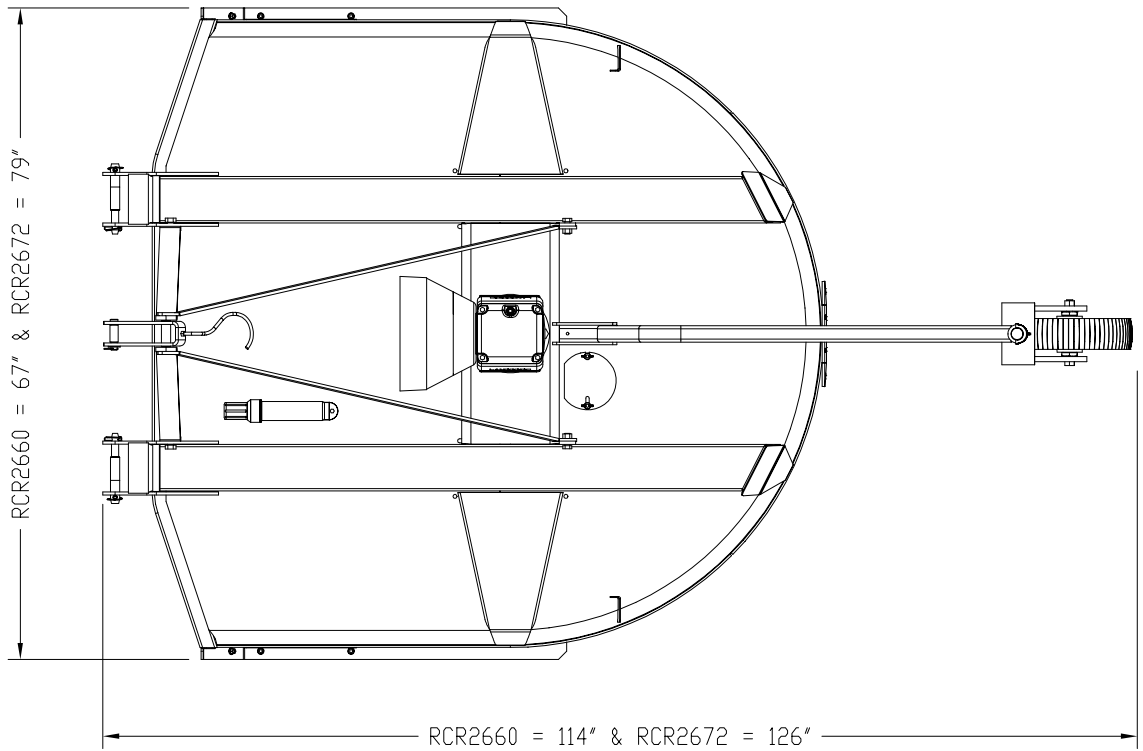

27559

Designs, specifications, features and information are subject to change without notice.