

Rotary Tillers

RTR05 Series		
Model	RTR0542	RTR0550
Recommended Tractor PTO HP	Up to 25 Horsepower (Subcompact Tractors)	
Weight	268#	298#
Tilling Width	42"	50"
Overall Width	46 1/2"	54 1/2"
Hitch Type	Category 0, Category I-Limited, and Category I Fits Land Pride's Category I Quick Hitch	
Offset Capabilities	No	
Number of flanges	5	6
Number of tines per flange	4	
Tine Construction	Alloy steel heat treated "C" shaped blades	
Skid Shoes	Adjustable	
Storage Stands	Adjustable	
Rear Deflector	Adjustable	
Driveline	Category II Off-Center Shear-bolt - standard Slip-Clutch - optional	
Gearbox	25 HP input at 540rpm 1.92:1 ratio Cast iron housing, straight bevel gears	
Gearbox Lubrication & Oil Capacity	1 Pint of SAE 80-90W EP oil	
Drive Chain	#80 Roller chain - Fully enclosed in oil bath with drain & fill plugs	
Drive Chain Lubrication	Shell Alvania EP 00 or equivalent	
Sprockets	Case hardened teeth, splined bores	
Rotor Swing Diameter	13"	
Rotor Shaft Speed	230 rpm at 540 rpm PTO	

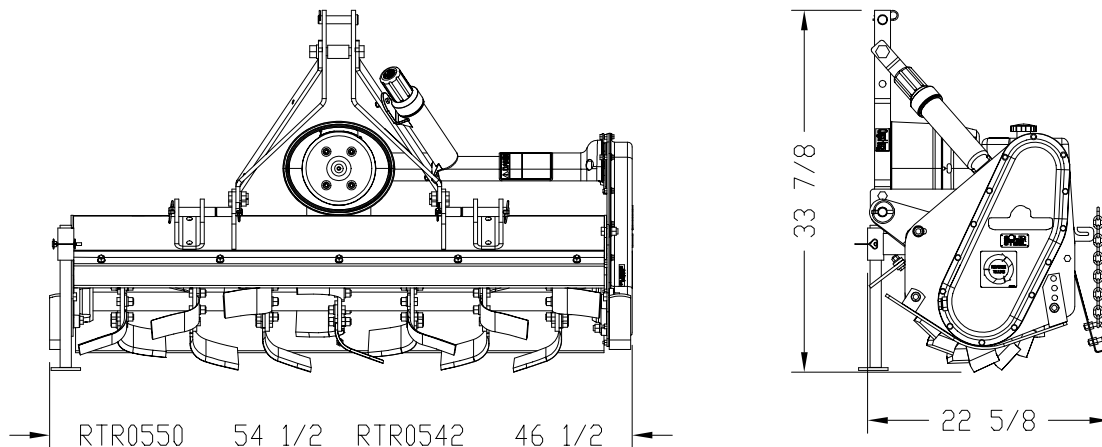

26794

Designs, specifications, features and information are subject to change without notice.