

Rotary Tillers

RTA10 Series			
	RTA1042	RTA1050	RTA1058
Recommended Tractor PTO HP	17 to 25 Horsepower (25 HP maximum)		
Weight	358 lbs.	385 lbs.	415 lbs.
Tilling Width	42"	50"	58"
Overall Width	47 1/4"	55 1/4"	63 1/4"
3-Point Hitch Type	Category I, Adjustable Lower Hitch Clevis with Plated Pins Fits Land Pride Quick-Hitch		
Offset Capabilities	Yes, Cannot offset with Quick-Hitch		
Sideshift Dimensions	Centered	16" - 26"	25" - 25"
	Shifted Right	16" - 26"	18" - 32"
	Shifted Left	23" - 19"	32" - 18"
Number of flanges	5	6	7
Number of Tines per Flange	4		
Tine Construction	Alloy steel heat treated "C" shaped blades		
Skid Shoes	Adjustable		
Storage Stands	Adjustable		
Rear Deflector	Adjustable profile stamped rear deflector		
Driveline	Category II Off-Center Shear bolt - standard Slip Clutch - optional		
Gearbox Construction	25 HP input at 540rpm 1.5:1 ratio Cast iron housing, straight bevel gears		
	Lubrication Capacity	Gear Lube 80-90W EP 2 pints	
Drive Chain	#80 Roller chain - Fully enclosed in oil bath with drain & fill plugs		
Drive Chain Lubrication	Shell Alvania EP 00 or equivalent		
Sprockets	Case hardened teeth, splined bores		
Rotor Swing Diameter	15"		
Rotor Shaft Speed	225 rpm at 540 rpm PTO		

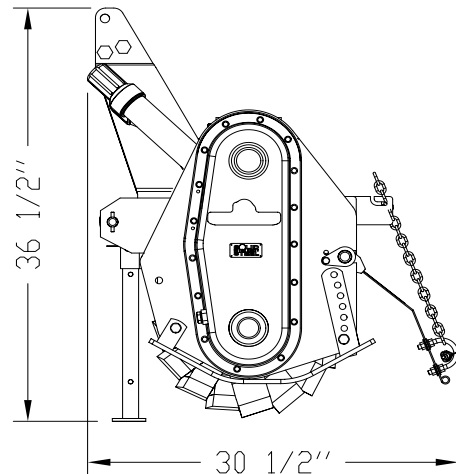
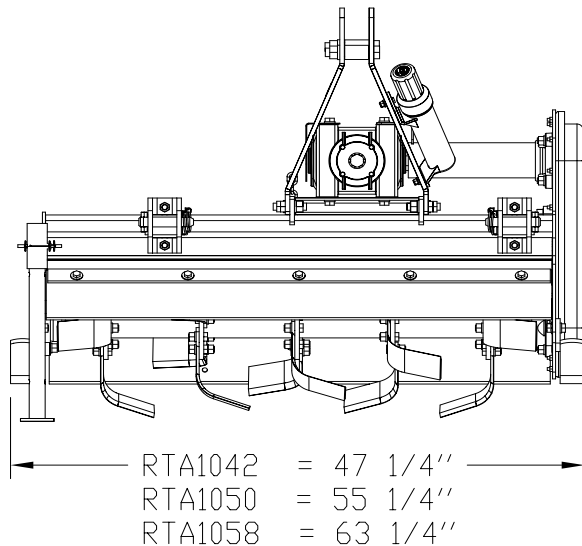

26982

Designs, specifications, features and information are subject to change without notice.

Rotary Tillers

RTA15 Series				
	RTA1550	RTA1558	RTA1566	RTA1574
Recommended Tractor PTO HP	17 to 35 HP		20-40 HP	25-50 HP
Weight	412 lbs.	444 lbs.	476 lbs.	508 lbs.
Tilling Width	50"	58"	66"	74"
Overall Width	56 1/4"	64 1/4"	72 1/4"	80 1/4"
Hitch Type	Category I, Adjustable Lower Hitch Clevis with Plated Pins Fits Land Pride Quick Hitch			
Sideshift Capabilities	Yes, Works with Land Pride Quick-Hitch			
Sideshift Dimensions	Centered Shifted Right Shifted Left	25" - 25" 12" - 38" 31" - 19"	29" - 29" 12" - 46" 35" - 23"	33" - 33" 12" - 54" 39" - 27"
Number of Flanges	6	7	8	9
Number of Tines per Flange	4			
Tine Construction	Alloy steel heat treated "C" shaped blades			
Skid Shoes	Adjustable			
Storage Stands	Adjustable			
Rear Deflector	Adjustable profile stamped rear deflector			
Driveline	Category III Heavy Duty Off-Center Shear bolt - standard Friction Clutch - optional			
Gearbox	Construction	50 HP input at 540 rpm 1.92:1 ratio Cast iron housing, straight bevel gears		
	Lubrication	Gear Lube 80-90W EP		
	Capacity	2 pints		
Drive Chain	#80 roller chain - Fully enclosed in oil bath with drain & fill plugs			
Drive Chain Lubrication	Shell Alvania EP 00 or equivalent			
Sprockets	Case hardened teeth, splined bores			
Rotor Swing Diameter	15"			
Rotor Shaft Speed	211 rpm at 540 rpm PTO			

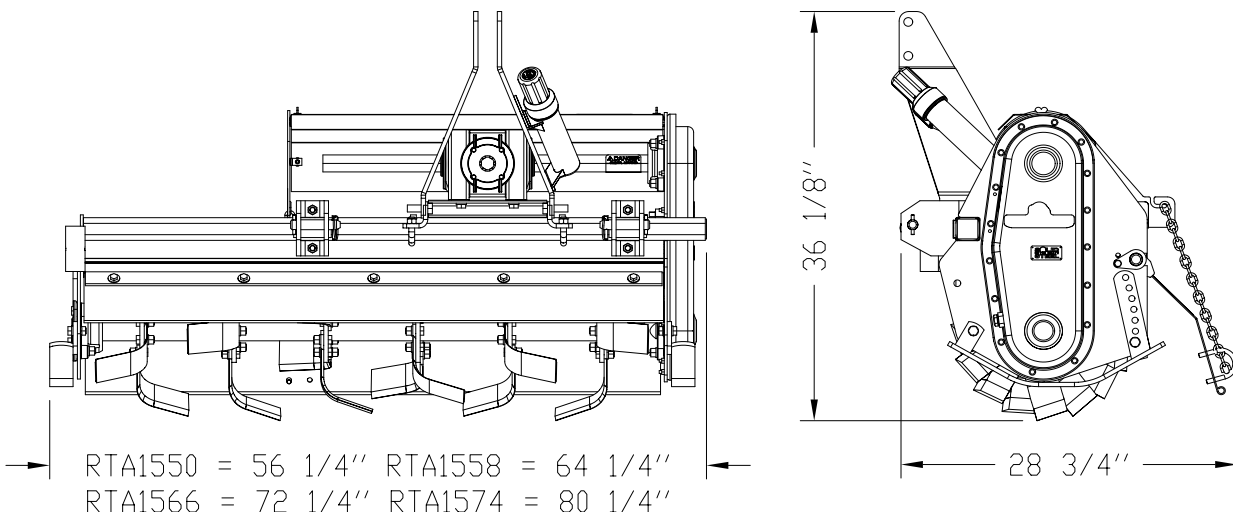

26983

Designs, specifications, features and information are subject to change without notice.