

**Box Scrapers**

**HR35 & HRL35 Series (Retractable)**

	19" Lowback HRL3578	24" Highback HR3584
Working Width	78"	84"
Capacity	26 cu. ft.	31 cu. ft.
Weight	972 lbs.	1117 lbs.
Weight (with hydraulics)	981 lbs.	1119 lbs.
Number of Shanks	8	8
Shank Material	3/4" x 2 1/2" heat treated spring steel	
Shank Penetration	3- positions (1", 3" & 5" below scraper end plates)	
Shank Tip Construction	Replaceable heat treated dimpled-on tips	
Shank Beam	Pivots to lift shanks up; transport lock on shank tube	
Lift Mechanism	Hydraulic cylinder	
Moldboard	Roll-Formed Moldboard -17"	Roll-Formed Moldboard - 23"
Side Panels	1/2" thick x 19" high x 30" deep	1/2" thick x 24" high x 30" deep
Depth of Bucket	28"	27 1/2"
Cutting Blades	2 ea. 1/2" x 6" high carbon, heat treated cutting edges; reversible and replaceable	
Maximum H.P. Rating	65 HP	
3-Point Hitch Construction	Harden bushings in upper and lower hitch points	
3-Point Hitch Type	Category I & II	

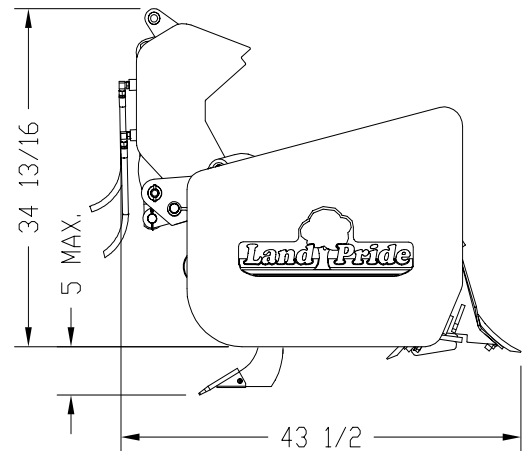
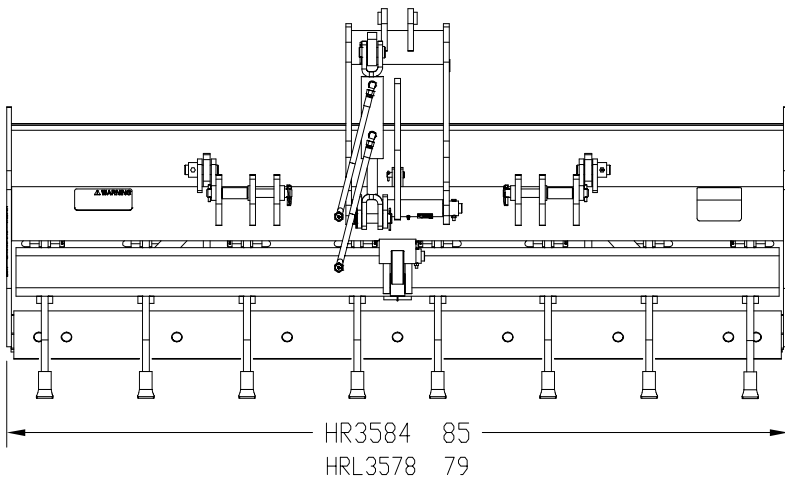

26995

MRL3572 Not Shown

Designs, specifications, features and information are subject to change without notice.