

Specifications & Capacities

Box Scrapers

BB15 Series

	BB1548	BB1554	BB1560	BB1566	BB1572
Working Width	48"	54"	60"	66"	72"
Capacity	9.8 cu. ft.	11 cu. ft.	12.2 cu. ft.	13.4 cu. ft.	14.7 cu. ft.
Weight (Pounds)	382	402	428	450	504
Number of Shanks	4	4	4	5	6
Shank Material	3/4" x 2 9/16" x 18" heat treated spring steel				
Vertical Shank Positions	4- positions (2 1/4" & 1/4" above and 1 3/4" & 3 3/4" below scraper end plates)				
Shank Tip Construction	Replaceable heat treated dimpled-on tips				
Shank Beam	4" x 4" x 5/16" Square Tubing with 5/16" x 1" full length shank reinforcements				
Lift Mechanism	Manual lift with shank pin & hairpin cotter at each shank				
Moldboard	Roll-formed moldboard - 16 3/4" High				
Side Panels	5/16" thick x 16" high x 24" deep				
Depth of Bucket	22"				
Bucket Reinforcement	Two welded braces to rear of bucket				
Cutting Blades	2 ea. 1/2" x 6" high carbon, heat treated cutting edges; reversible and replaceable				
Maximum H.P. Rating	25 Hp				
A-Frame Material	1/2" x 3" HR 1021				
3-Point Hitch Type	Double strap lower hitch Cat. I (Fits Land Pride Quick Hitch)				

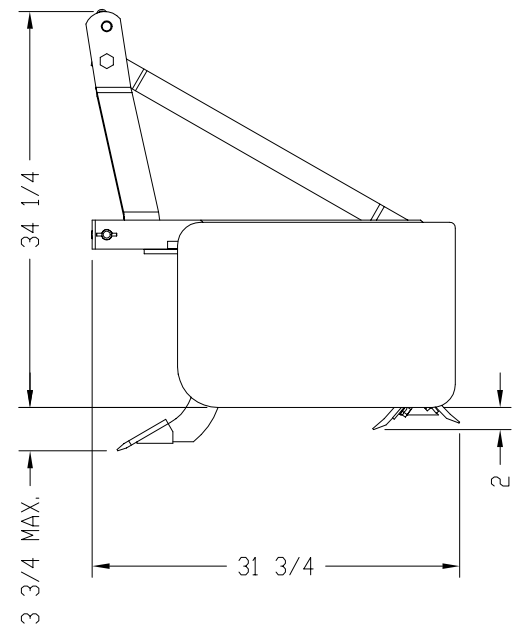
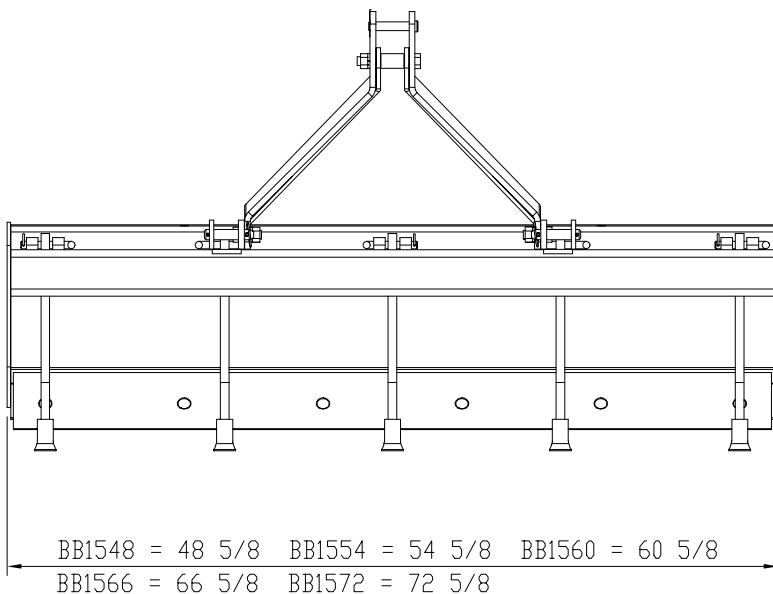

26746

Designs, specifications, features and information are subject to change without notice.

Box Scrapers

BB25 Series

	BB2560	BB2566	BB2572	BB2584	BB2596
Working Width	60"	66"	72"	84"	96"
Capacity	12.2 cu. ft.	13.4 cu. ft.	14.7 cu. ft.	17.1 cu. ft.	19.6 cu. ft.
Weight (Pounds)	471	500	549	593	658
Number of Shanks	5	5	7	7	8
Shank Material	3/4" x 2 9/16" x 18" Heat Treated Spring Steel				
Vertical Shank Positions	4- positions (2 1/4" & 1/4" above and 1 3/4" & 3 3/4" below scraper end plates)				
Shank Tip Construction	Replaceable heat treated dimpled-on tips				
Shank Beam	4" x 4" x 5/16" Square tubing with 5/16" x 1" full length shank reinforcements				
Lift Mechanism	Manual lift with shank pin & hairpin cotter at each shank				
Moldboard	Roll-Formed Moldboard - 16 3/4" High				
Side Panels	3/8" thick x 16" high x 24" deep				
Depth of Bucket	22"				
Bucket Reinforcement	Two Welded Braces to Rear of Bucket Gusset Between Side Panel and Moldboard				
Cutting Blades	2 ea. 1/2" x 6" high carbon, heat treated cutting edges; reversible and replaceable				
Maximum H.P. Rating	40 HP				
A-Frame Material	1/2" x 9" A36 Flat Bar				
3-Point Hitch Type	Double strap lower hitches Cat. I (Fits Land Pride Quick Hitch)				
Vertical Shank Positions	4				

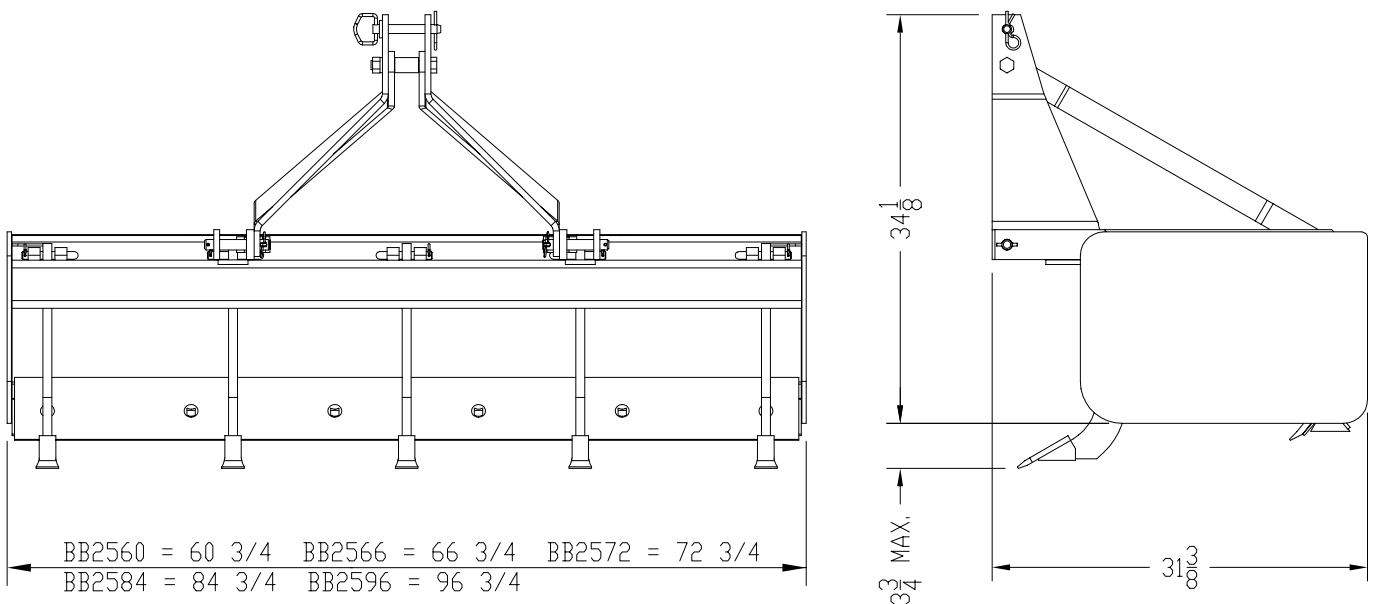

27520

Designs, specifications, features and information are subject to change without notice.